



SINGLE HOUSE



TABLE OF CONTENTS

| | |
|---|----|
| BEFORE YOU BEGIN: Inventory and Sort | 3 |
| PHASE ONE: Slab | 4 |
| PHASE TWO - A: Framing | 7 |
| PHASE TWO - B: Wall Prep & Roofing | 17 |
| PHASE THREE: Stucco | 24 |

BEFORE YOU BEGIN

Inventory and Sort

Welcome to your Amor Ministries building project! This is your guide to the construction process. It is continually updated, so even if this is not your first project, please read these instructions to familiarize yourself with recent changes. If this is your first project, we recommend that you keep this entire manual handy, along with the tri-fold Site Foreman's Guide, which contains good tips for getting your entire build crew involved. They are both designed to help you progress step-by-step through the construction process.

STEP 1. AT THE SITE

The homeowner has already determined where the home is to be built. They have taken into consideration their neighbors, existing structures, and their family's needs. Please make every effort to honor their requests. It's always helpful to sketch out the floor plan, including the positioning of doors and windows in accordance with the family's wishes. They have already worked to level the work site. Clear the area for the slab. Don't assume anything; ask where to place all items cleared from the work area.

Check for a water source in case the family is relying on deliveries or borrowed barrels.

STEP 2. MATERIAL INVENTORY

In the days prior to your arrival, all the materials for the project were delivered to the work site. Using the material checklist provided below, locate and inventory everything necessary to complete the project.

- o 38 – 12 ft. two-by-fours (Barrotes)
- o 100 – 8 ft. two-by-fours (Barrotes)
- o 11 – 10 ft. one-by-fours (Latilla)
- o 9 – Plywood (Petatillo)
- o 4 rolls – Felt paper (Felpa)
- o 4 rolls – Roll roofing (Arenado)
- o 2 rolls – Chicken wire (Alambre de pollo)
- o 8 kgs. – Bailing wire (Alambre recosido)
- o 30 – 42.7 kg. Bags cement (Cemento)
or 25 – 50 kg. Bags
- o 18 – Mud sill anchors (Anclas)
- o 8 – Hurricane straps (Soportes del techo)
- o 3 bags – High Tech fibers (Fibra)
- o 14 kgs. - 1 bag 16-penny nails
(Clavos grandes)
- o 5 kgs. - 1 bag 8-penny nails
(Clavos medianas)

- o 10 kgs. - 1 bag 1 ¼ in. Roofing nails
(Tachuelas)
- o 1 – Brush (Brocha)
- o 1 gallon – Roofing tar (Brea en frio)
- o 6 meters – Sand and gravel (Arena y grava)
- o 2 – Windows (Ventanas)
- o 1 – Door (Puerta)
- o 3 – Hinges (Visagras)
- o 1 – Door knob (Chapa)
- o 6 – Family provides water barrels
(La familia proporciona tambos de agua)

STEP 3. SEPARATE AND SORT THE LUMBER

The most common mistake occurs when cutting lumber and plywood. **It is very important to avoid cutting the 12 ft. 2x4s needed for the roof. Find 18 straight and strong 12 ft. boards for the roof** (no large knots or splits). Mark and set them aside so that they won't be cut or used for anything else.

* **Note: Check 8 footers and 12 footers for uniform length!**

* **See site Foreman's Guide for more time saving tips.**

NAIL DIAGRAMS

1 ¼ in. Roofing Nail

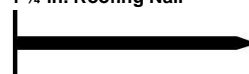

8-penny (2 ½ in.)



16-penny (3 ½ in.)



*Standard Measurement Abbreviations

8 Feet = 8 ft. = 8'

8 Inches = 8 in. = 8"

two-by-four = 2x4

one-by-four = 1x4

PHASE ONE

STEP 4. DIG A FOOTING TRENCH AROUND THE INSIDE OF THE FORM (D2)

The footing anchors the foundation to the ground and keeps it from shifting. The trench should be **no larger than 8 in. wide x 10 in. deep** measured from the **TOP** of the form. Use a round shovel for this step. Square tip shovels make the trenches too big.

STEP 5. LEVEL THE SOIL (D2)

Place a 12 ft. 2x4 on edge across the top of the form, and measure the distance from the bottom of the 2x4 to the leveled ground. This will show how thick the cement will be. Add or remove dirt until the distance is between 3 and 4 inches. Note: Soft ground will compact when you walk on it. Make sure the ground is compact when measuring the slab depth so the slab will not be too thick.

You can use a 2x4 (actually 3½ in. wide) on edge to measure the gap underneath. You can nail an 8ft. 2x4 on edge to the bottom of the 12 ft. board to create a depth gauge for leveling the pad area. An inverted steel rake whose points are approximately 3 ½ in. high can also be dragged under the 12 footer as a depth gauge for leveling the dirt.

STEP 6. MIX THE CONCRETE

When the form is level and square, it's time to mix. Mix in a wheelbarrow, or in a mixing bin. The ratio is: five shovels of sand and gravel to every one shovel of cement; make sure to be consistent with the size of scoops. Larger amounts can be mixed as long as the ratio is 5:1. If rocks and sand are separate or if the pile is unevenly mixed, **try to use three sand and two rock to every one cement**. Add the High Tech fibers at 1/5 bag of fiber to one sack of cement. Use all three bags to complete the slab. This means you should have used one bag of fiber by the time you complete 1/3 of the slab. If not, increase the amount of fiber you're adding to the mix. **Completely mix the dry materials before adding water, achieving an even color and texture.** Add water gradually and mix until a consistency of oatmeal is attained. Pour the concrete into the form, working from one end to the other, leveling as you go. **Don't bump the form out of square or level!**

Concrete can get pretty hectic. It helps to lay a 12 ft. board across the form (starting perhaps 2 ft. away from one end) and instruct workers to dump concrete only on the opposite side.

STEP 7A. TAMP AND SCREED THE CONCRETE (D2)

This is the process which creates a flat, level surface of concrete. Once you have poured a couple feet of concrete, take a **straight** 12 ft. 2x4 (this is your screed board) and place it on edge at the

D1

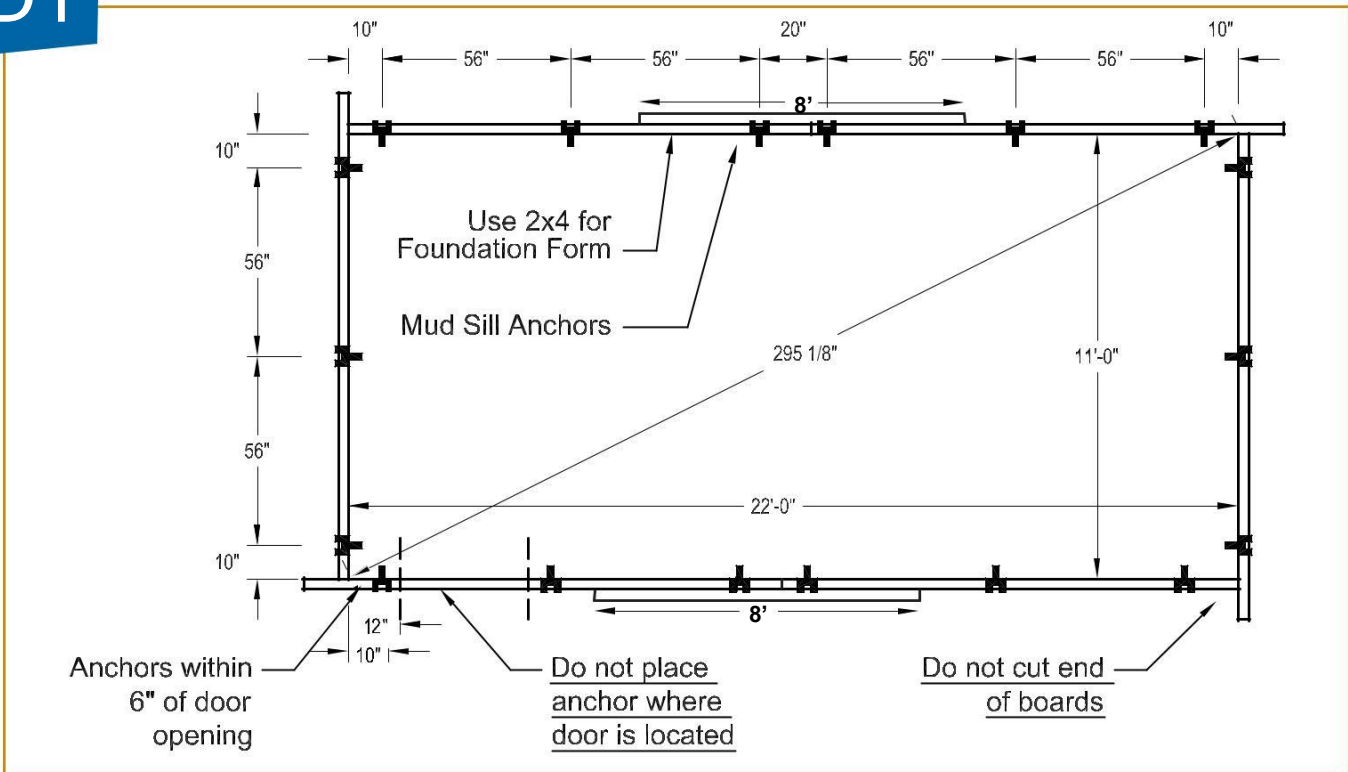

beginning of your slab. Tamp the concrete by lifting one end of the screed board and striking the concrete (alternate sides). This forces rocks down from the surface and brings water up. Tamp rhythmically (and firmly), working from the beginning to the leading edge of the poured concrete. Make sure that both ends of the screed board touch the form; if they don't, you must remove concrete to make it level.

After tamping, screed the surface as follows: two people should take the same board, start again at the beginning, and "saw" the board back and forth between them, moving slowly toward the leading edge of concrete (See Diagram 2). Keep the board in contact with the form. This will push a lot of concrete off the top, and may require another person to help pull concrete away. It may take several passes to make the surface smooth, and you may need to screed it again later if it is disturbed, or puddles of water form on the surface.

STEP 7B. PLACE THE MUD SILL ANCHORS (D1 & D3)

Anchors are used to secure the walls of the house to the foundation (Diagram 1). As you pour concrete down the form, you can place anchors in the area already tamped and screeded. The mud sill anchors are placed 10 in. from each corner and equally spaced along the edge of the slab, three anchors in each 11 ft. section (See Diagrams 1 & 2).

DO NOT PLACE AN ANCHOR IN YOUR DOORWAY!

STEP 7C. TROWEL THE CONCRETE

Concrete at this point can be very different depending on quality and coarseness of materials, timing and quality of screeding, and time of day and temperature. If the surface after screeding is still

rocky, tamp it again and more firmly! Next, you will need to trowel it with floats (trowels made of wood or magnesium) to get an even surface. Once the surface is fairly smooth, it is best to leave it alone for 20 to 30 minutes. **The best finish is obtained when the concrete has been allowed to dry until it is no longer shiny.** When you are ready, use finish trowels (large, smooth metal trowels) to make the surface completely smooth. Using scrap wood to stand on, begin from the center of the slab and work your way out, smoothing over your own board marks as you move. Apply a little water where necessary (spray bottles are handy). Tip up the leading edge of the trowel and use lots of downward pressure. This is the secret to good finish troweling. Use the trowel as you would a butter knife: more angle for scraping, less angle for smearing.

PROPER ANCHOR PLACEMENT!

D3



D2

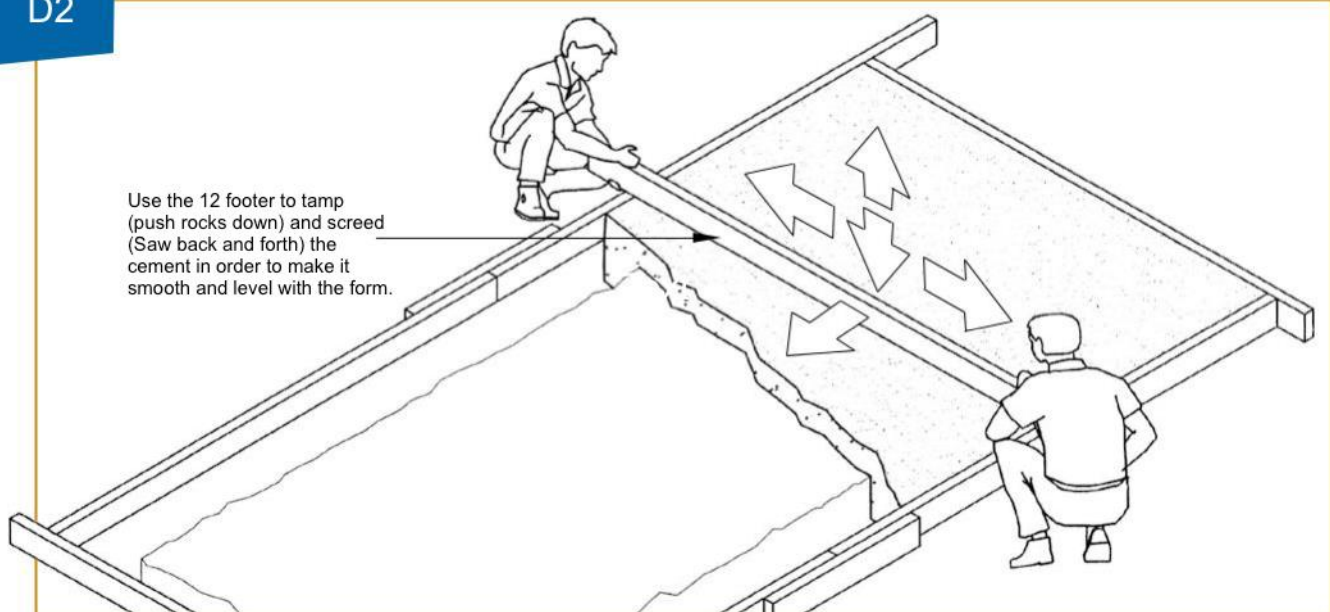

STEP 2C. ADD A WINDOW OPENING TO A WALL (D8 & D9)

First, verify the style of your project's windows

Not all but most Windows used by Amor Ministries are 24" tall by 48" wide. To frame the window opening Cut two pieces of 2X4 to 24" long. Some of The windows we use have a channel on either side that you will slide the two pieces you just cut into.

!Check window style! Not all of the windows we receive from our vendors have a channel

Now measure from the outside of the wood across the window to the outside of the other side to get your width, and measure from the bottom of the window to the top and this measurement will be your height. Add a 1/2" onto these measurements and this will be your rough window opening

. **(Example: If the window size is 24" wide by 36" tall, you will frame the opening 24 1/2" X 36 1/2")**

Measure from the bottom of the bottom plate, mark the two studs at 4ft. this will be the inside of the bottom plate for your window opening. Nail a board measuring a half inch larger than your actual window size below this line and then measure from there to get the position of your top board. **(See Diagrams 8&9)**

STEP 3. ADD THE CALIFORNIA CORNERS (D11 & D4-D10)

On both ends of each 11 ft. straight wall section, add a California corner. This is done by placing a 2x4 at right angles to the outside stud. Nail into the 11 ft. plate at both ends and to the outside stud in at least three places (See Diagram 11 or Diagrams 4 through Diagram 10 — shaded areas indicate California corners). **When the walls are raised, the California corners must be flush to the inside of the house.**

STEP 4. BUILD THREE RAKE WALLS (D12-D17)

Consult with the family regarding the placement of any doors (especially the interior rake wall doorway) or windows in the rake walls and then refer to Steps 2b and 2c. Start with a 10 ft. 5 in. 2x4, a 10 ft. 5 5/8 in. 2x4, an 8 footer, and a 7 footer. The 10 ft. 5 5/8 in. board will be the top plate of the wall and the 10 ft. 5 in. will be the bottom plate. Nail these together (Diagram 12 – 17). Square the two bottom corners and nail a block diagonally across each to keep it square. Make marks every 2 ft. on the 10 ft. 5 in. side, as you did for the 11 ft. walls. Select one very straight 8 ft. 2x4 and place one end on each mark in turn. Square this board with the bottom plate, than mark it at the top plate to indicate where the stud should be nailed. Then measure the distance between top and bottom and cut a different board to fit. Keep the straight board for measuring each stud. Repeat to build two more walls. **Rake walls do not need California corners.**

STEP 5. ADD FIRE BLOCKS TO THE WALLS (D4-D17)

Fire blocks are necessary to make the house more rigid, and to provide a place to nail the outer covering of the house to the walls. Put three fire blocks between every two studs in every wall, **except for the interior (center) rake wall.** The fire blocks should be spaced 2 ft. apart and staggered slightly for easier nailing. Mark

at the 2 ft., 4 ft., 6 ft. levels, and alternate nailing the fire blocks on the top or bottom of the line giving a staggered difference of 1 3/4 in. on each block (See Diagram 4-10). **Do not allow fire blocks that are too long to bulge end wall studs or door and window openings. Also, there are two exceptions where four fire blocks are needed (See Diagrams 12 & 16).**

STEP 6. BUILD THE ROOF SECTIONS (D18)

Take the 18 12 ft. 2x4s that were laid aside earlier and cut 14 boards to 11 ft. 9 in. Make sure the remaining four 2x4s are exactly 12 ft. If you have less than 18 of the 12 ft. boards or if all were cut to 11 ft. 9 in. in error, consult your Amor Team Member. Take two of the 12 ft. 2x4s and place them face-to-face on edge, flush on both ends. Measuring from one end, make a mark every 2 ft. on both 12 ft. boards. **Nail an 11 ft. 9 in. 2x4 centered on each mark. This is different than the walls, and is absolutely crucial if the plywood is to fit the roof well.** Finally, nail three 2 1/4 in. 2x4s between the first and second rafters, spaced 3 ft. apart on one end only of each roof square. These are called outriggers and are for the support of the outside rafter. No fire blocks are needed on the roof, only bird blocks (Phase Two-B, Step 5) and outriggers. Build two identical sections at these specifications (See Diagram 18). Bird blocks may be pre-measured, pre-cut and numbered to each opening to speed up later assembly. **Do not install bird blocks until the roof sections have been placed on the walls, squared, and nailed down.**

NOTES:

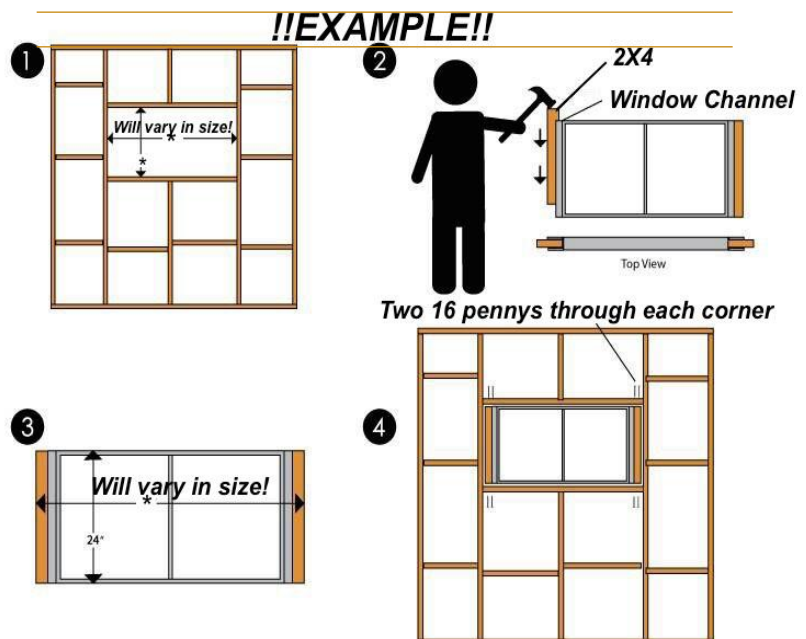

D4

Outside View of Wall

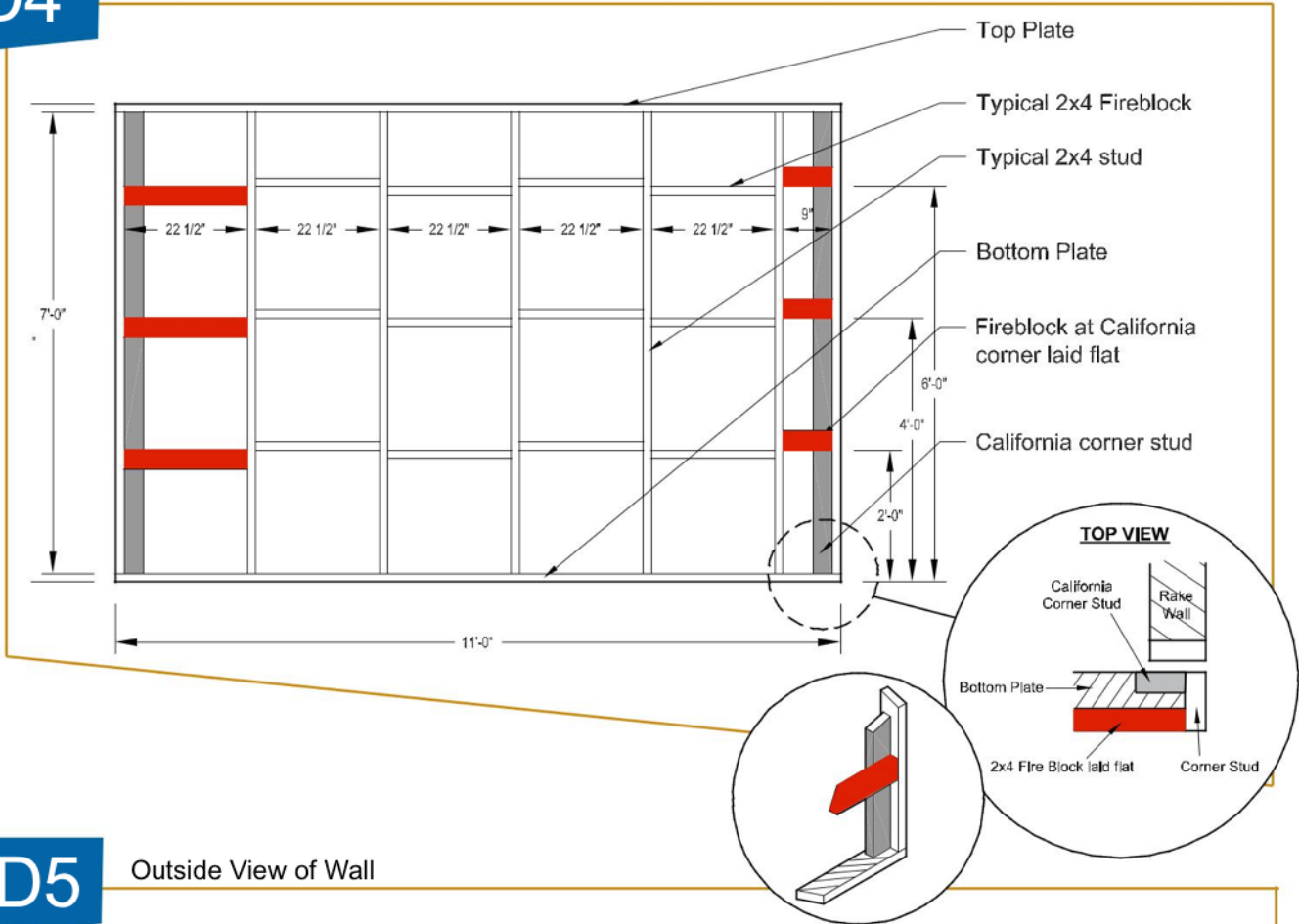

D5

Outside View of Wall

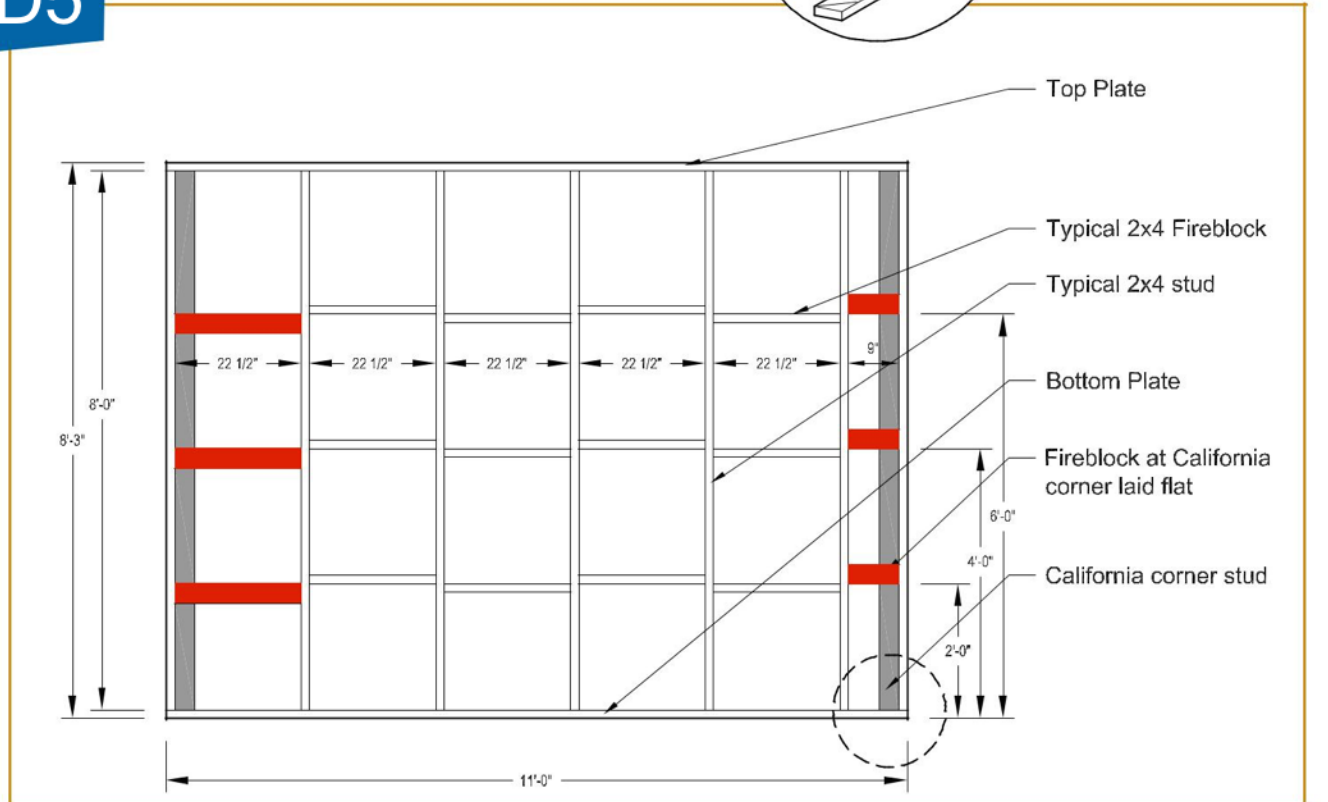

D6 Outside View of Wall

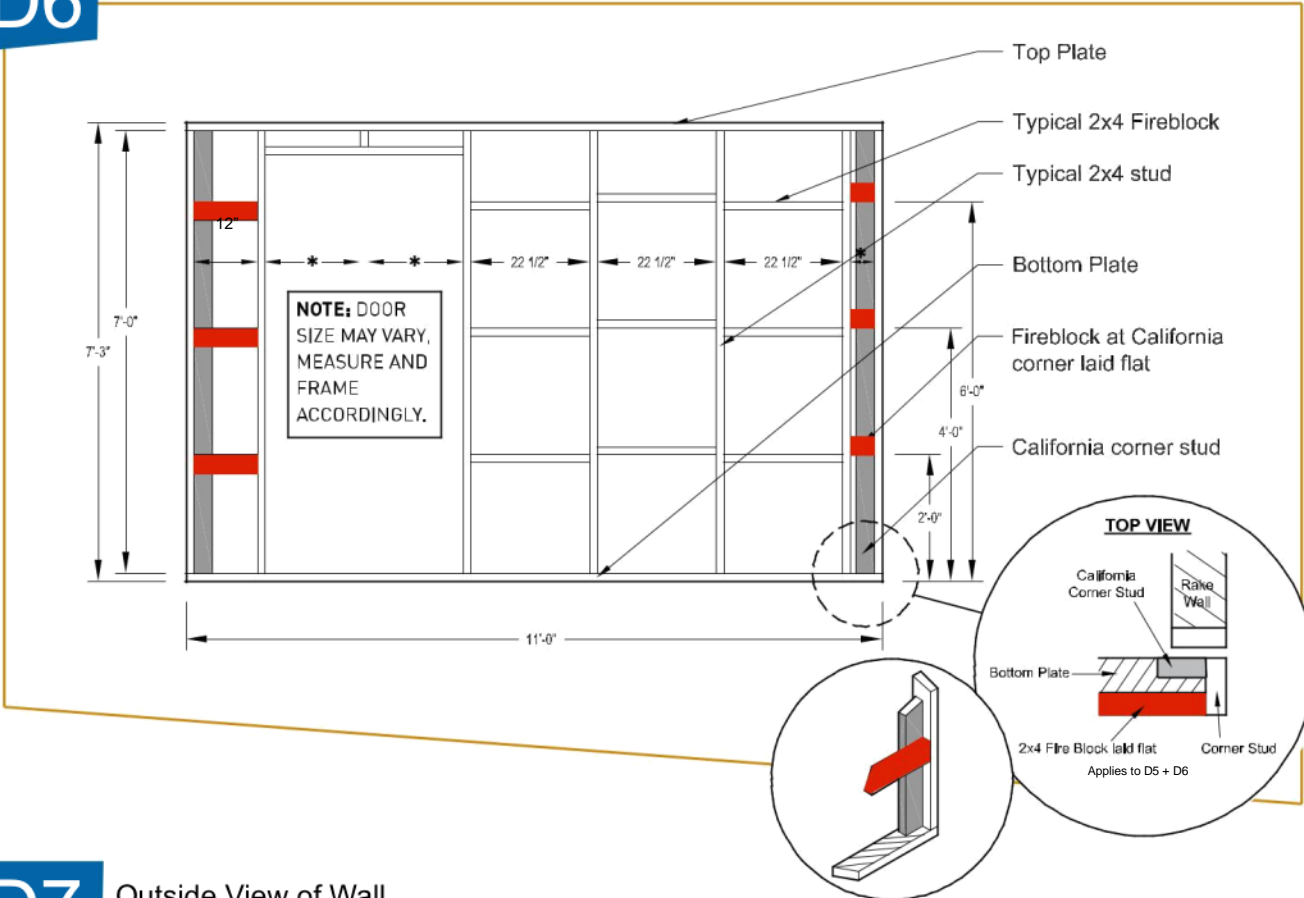

D7 Outside View of Wall

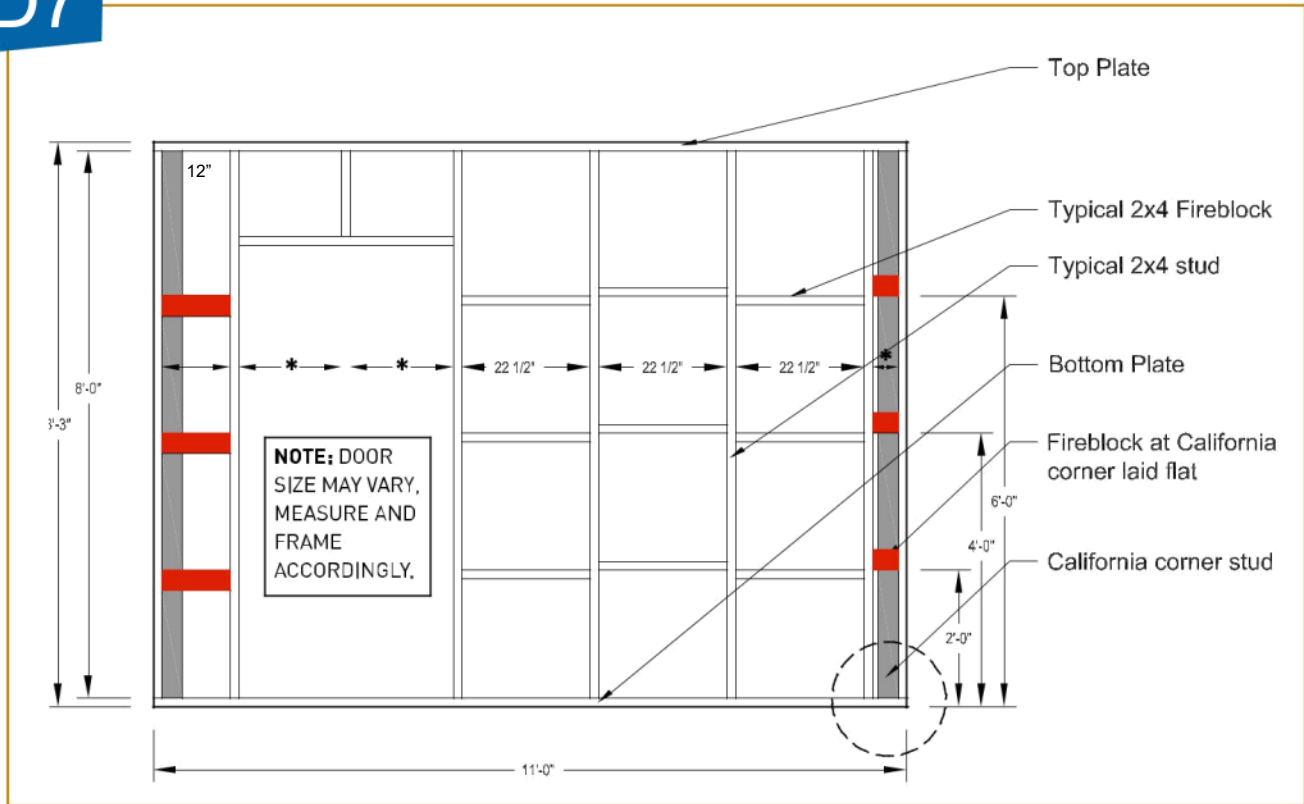

D8

Outside View of Wall

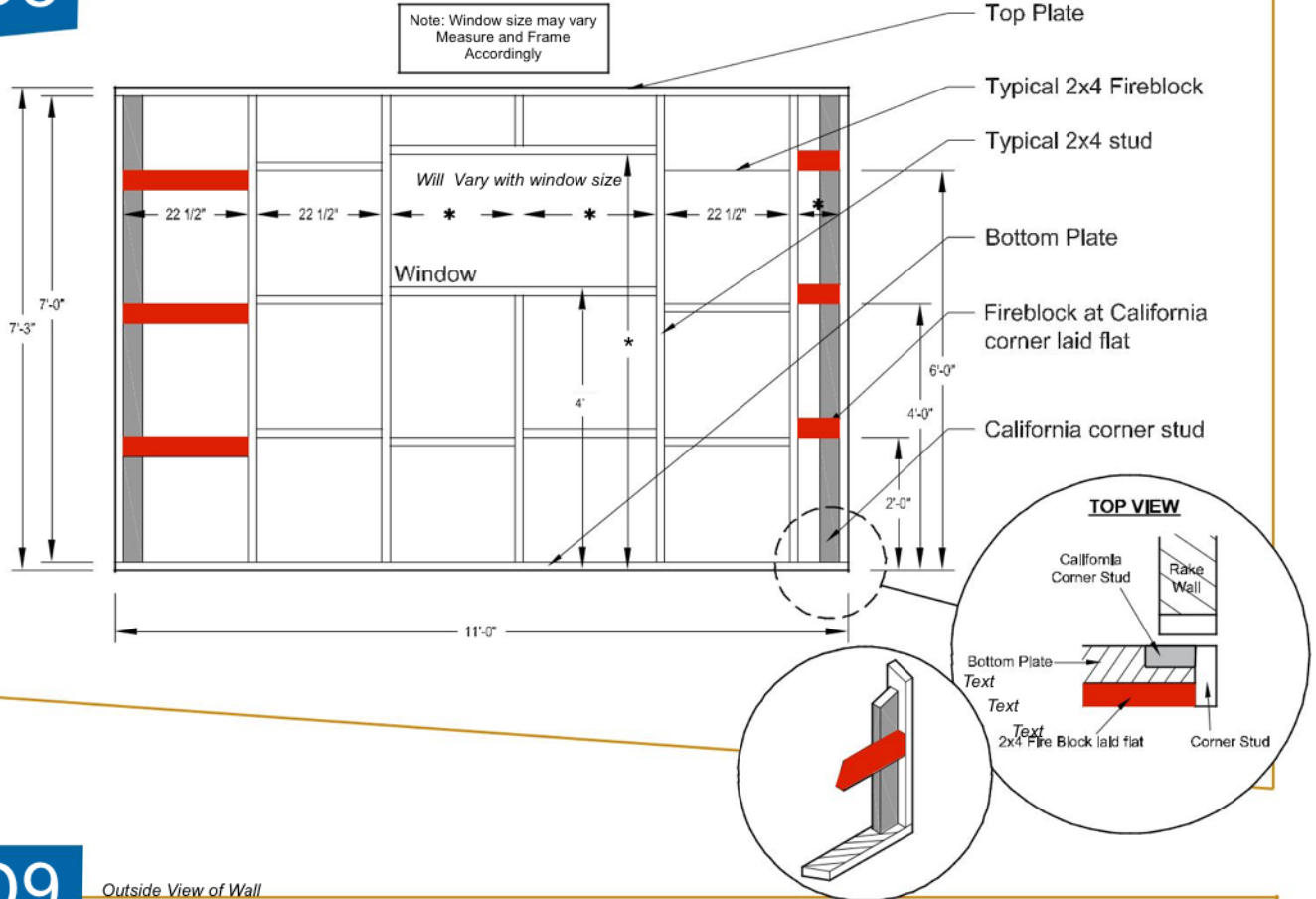

D9

Outside View of Wall

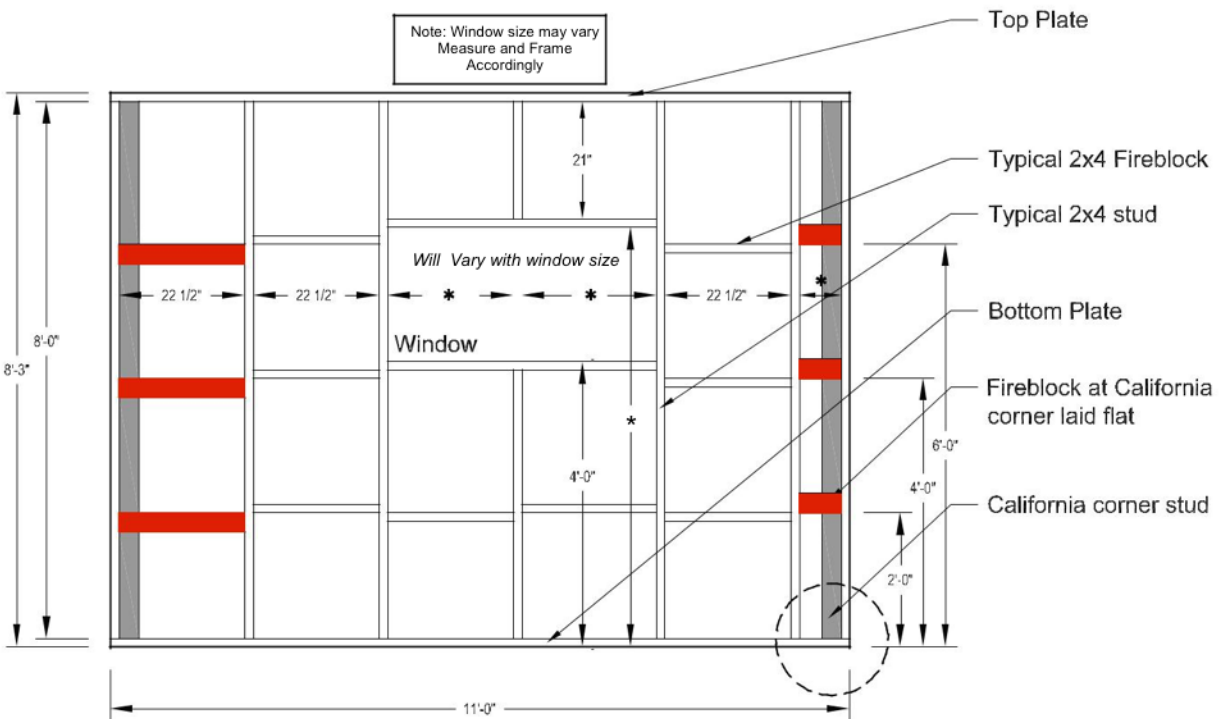

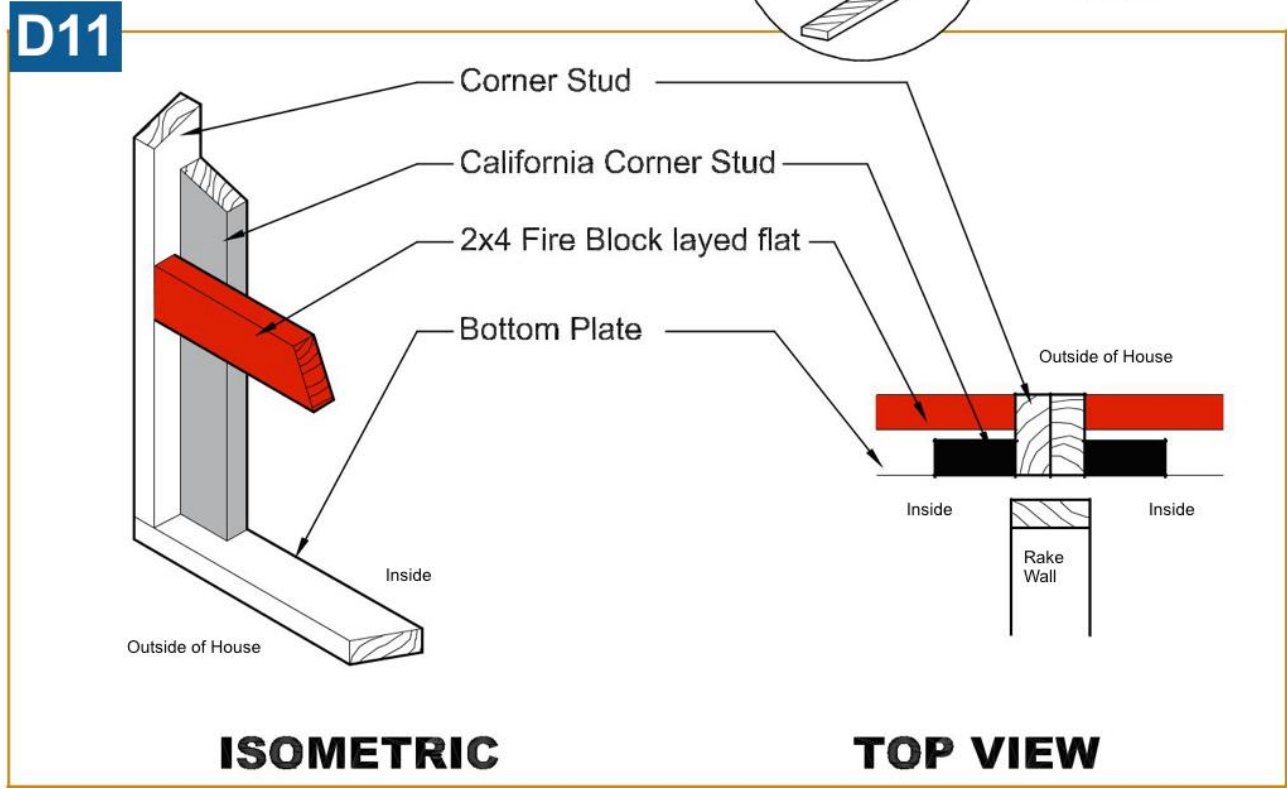
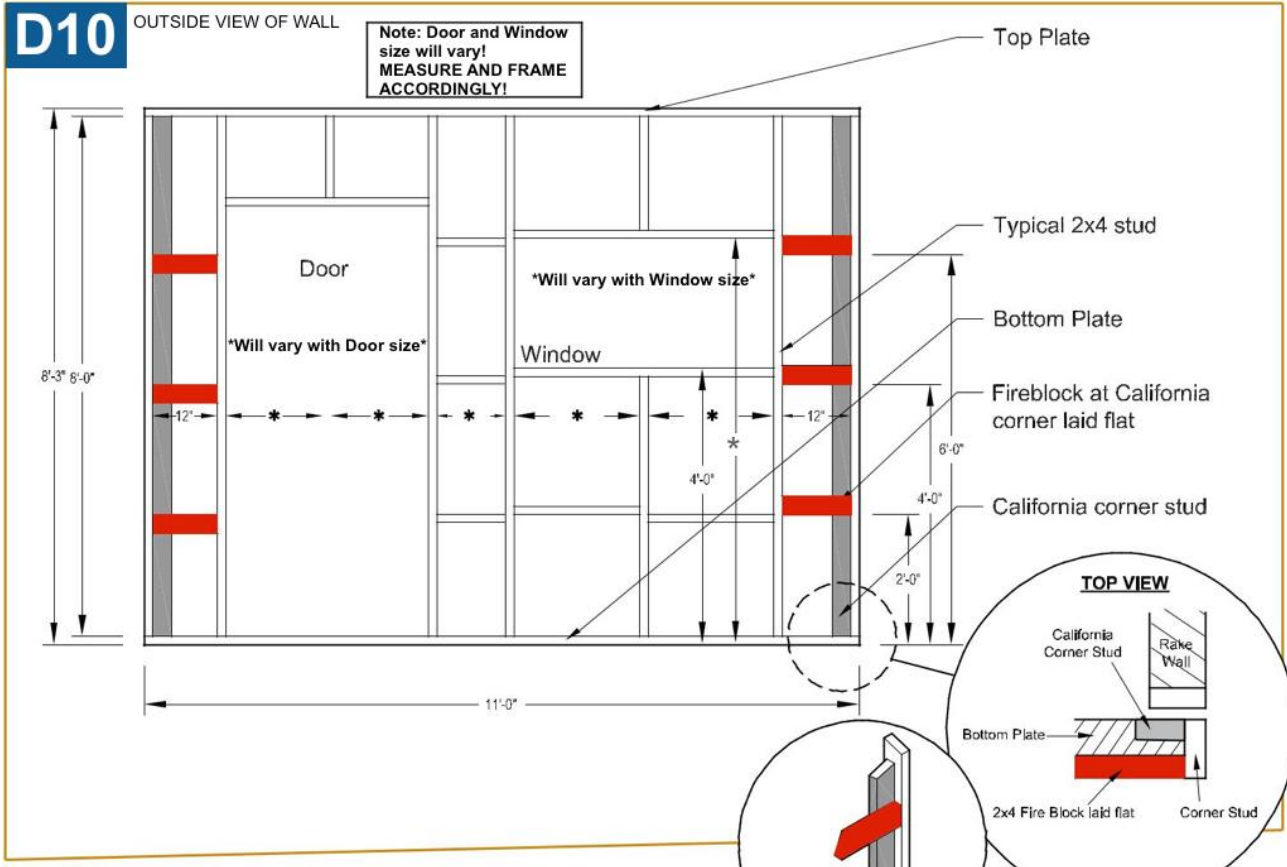

D12

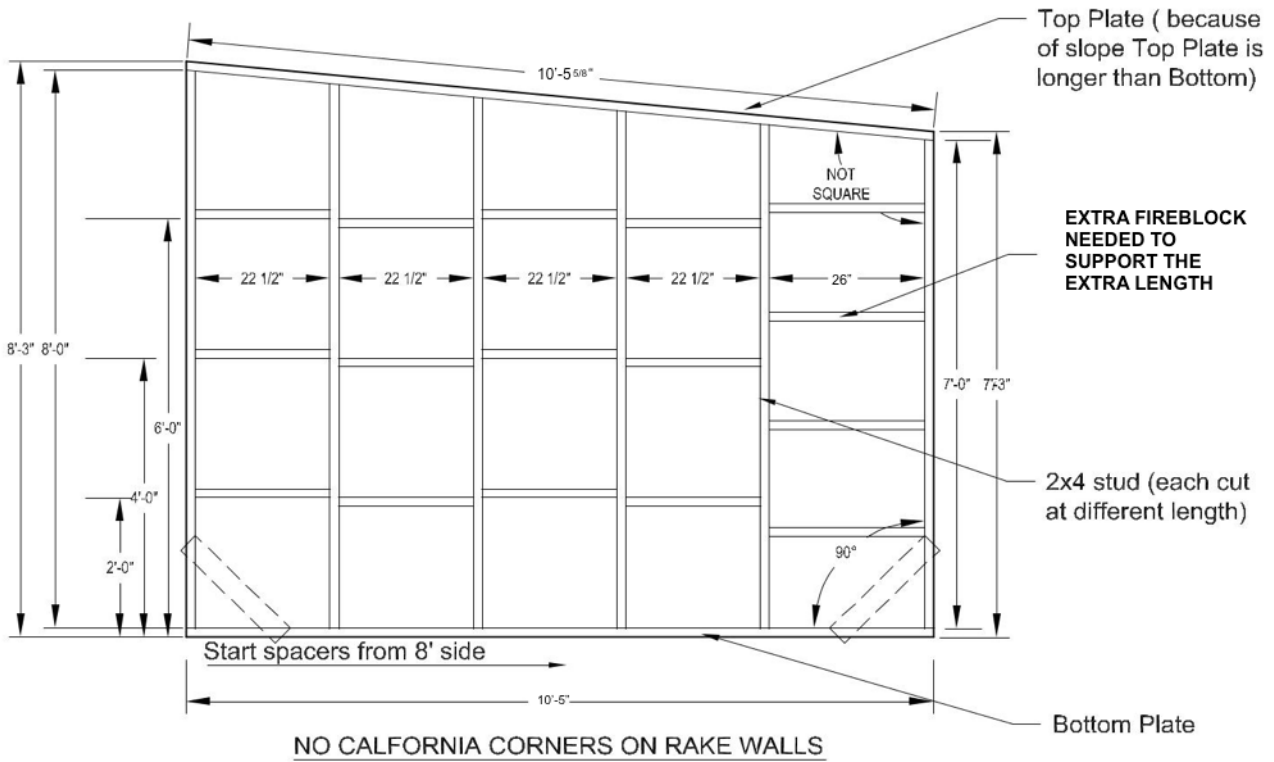

D13

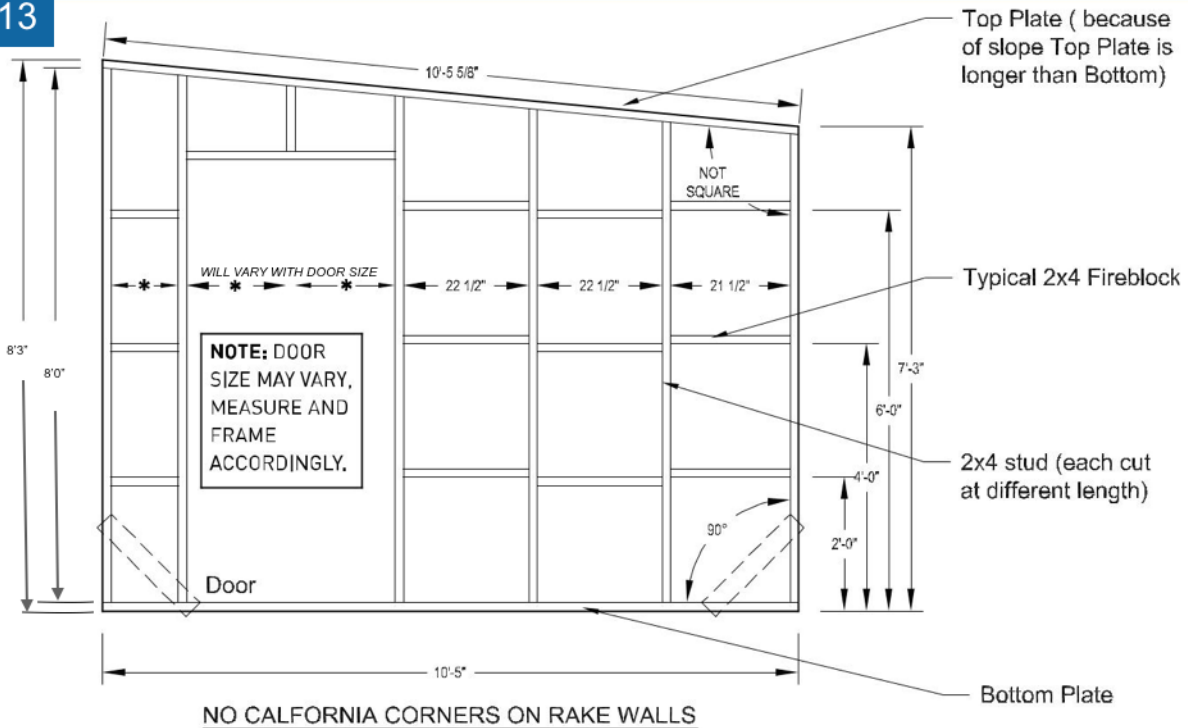

Phase Two -A

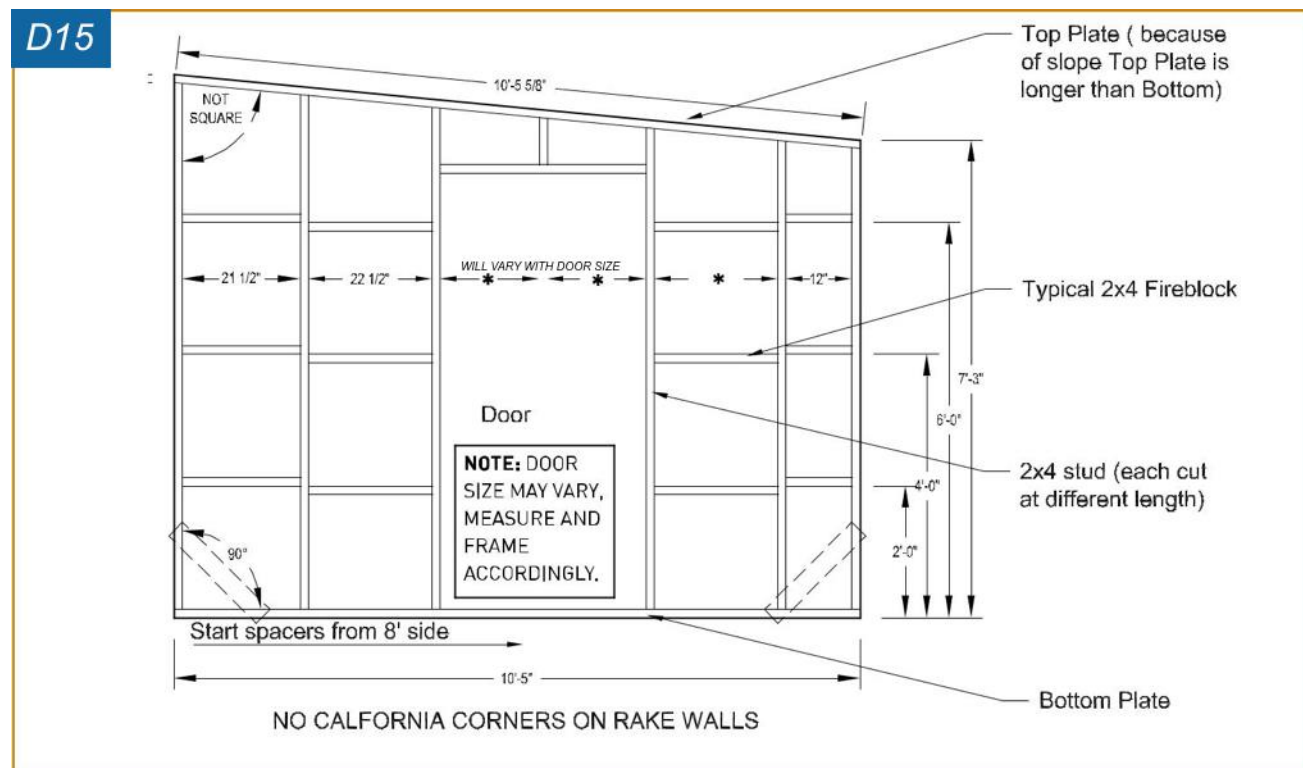
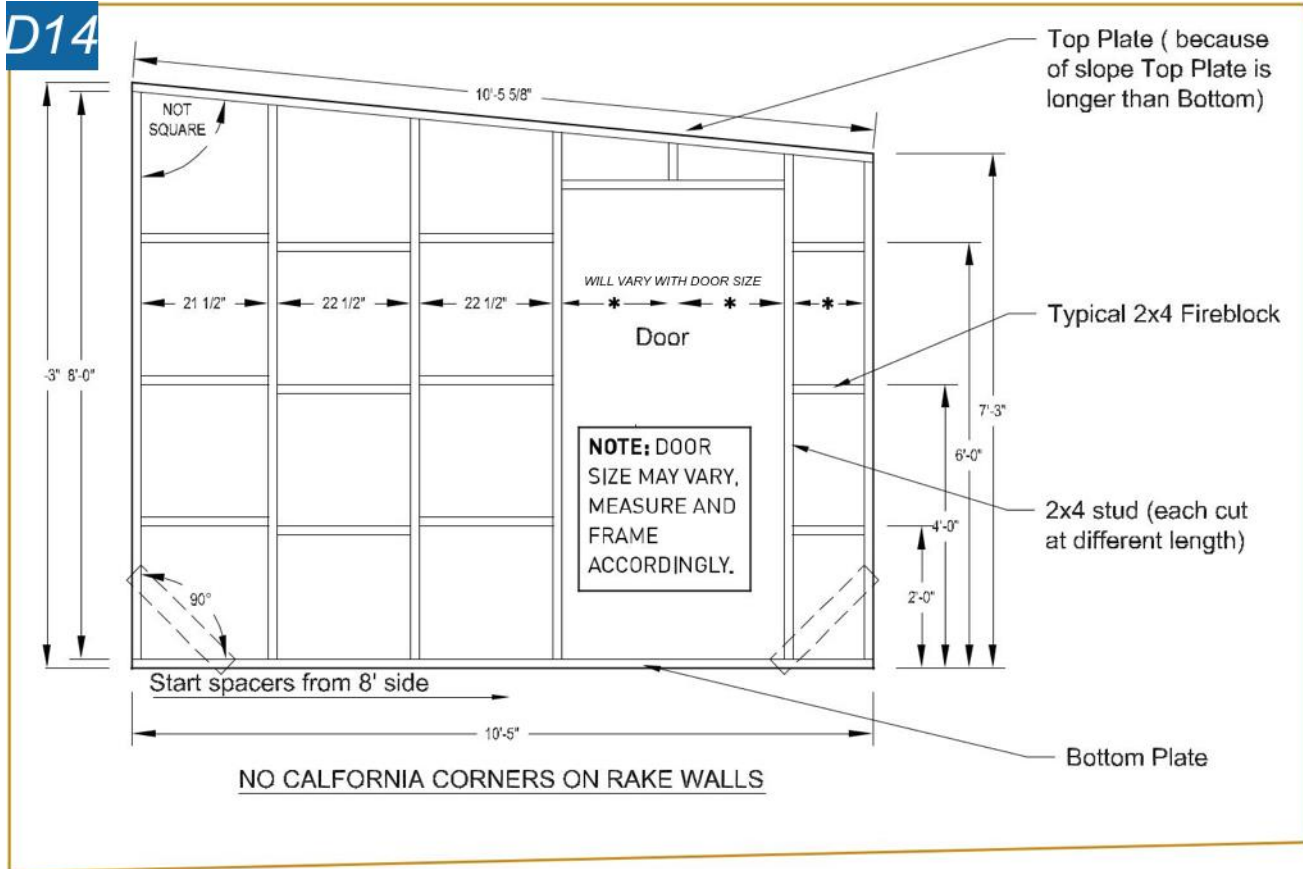

D16

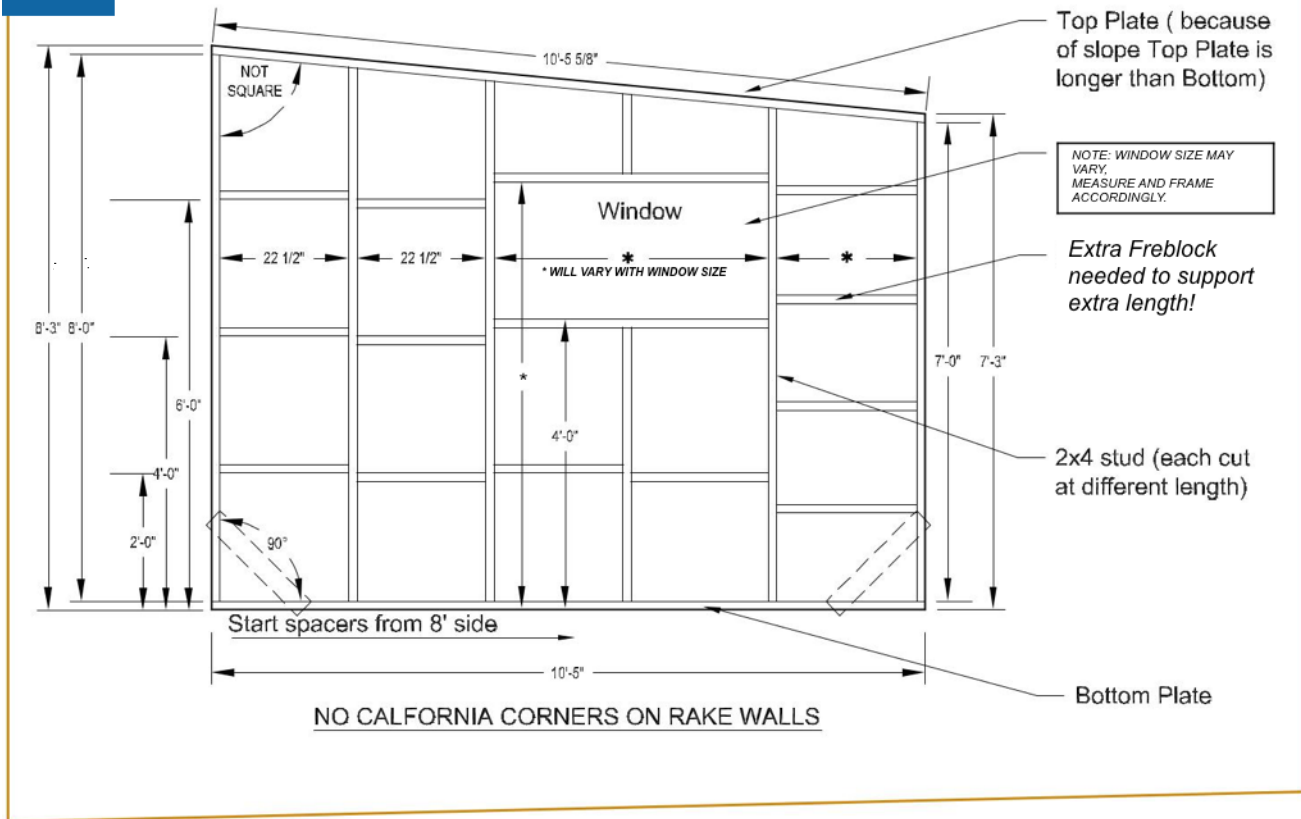

D17

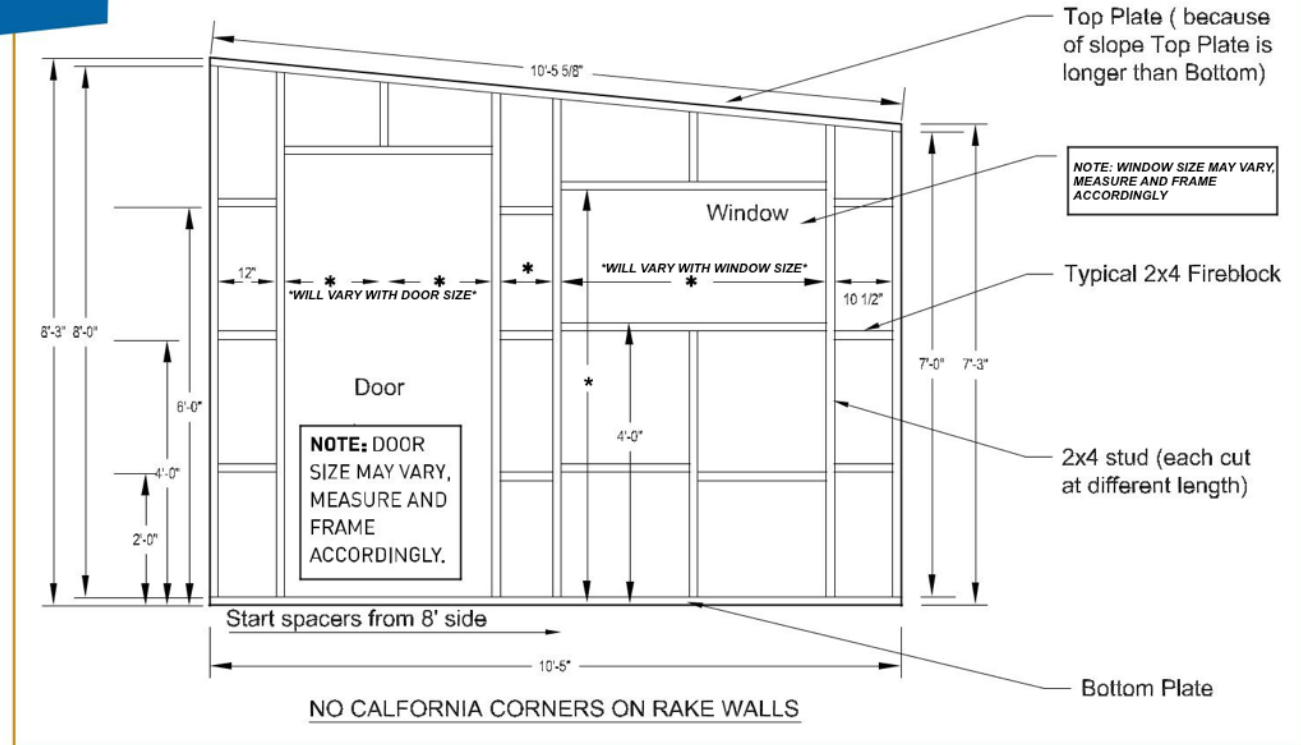

D18

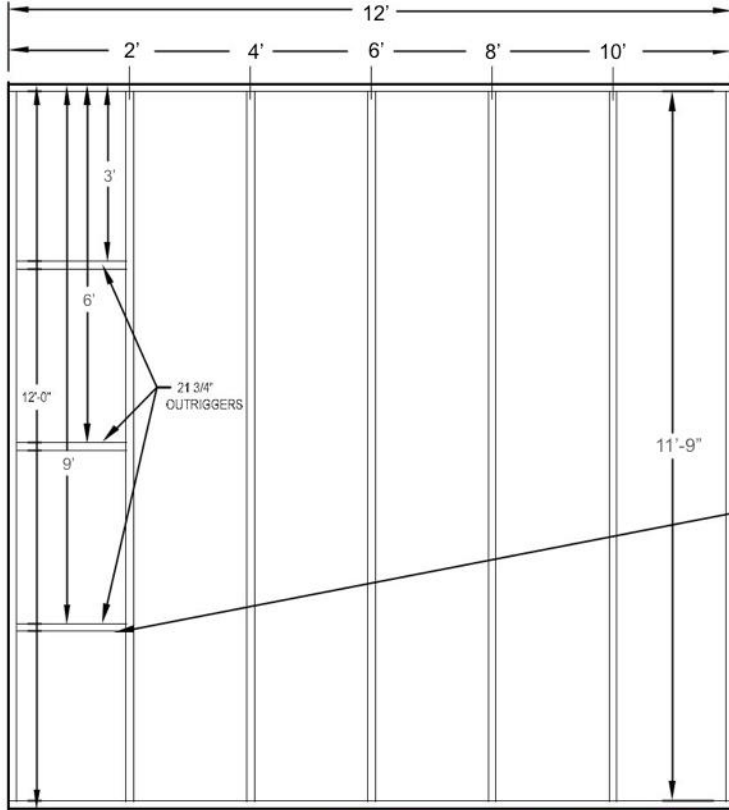

Nail an 11ft. 9 in. two-by-four rafter centered on each mark. This is different than the walls, and is absolutely crucial if the plywood is to t the roof well.

Typical Outrigger

On-Center Nailing Instructions

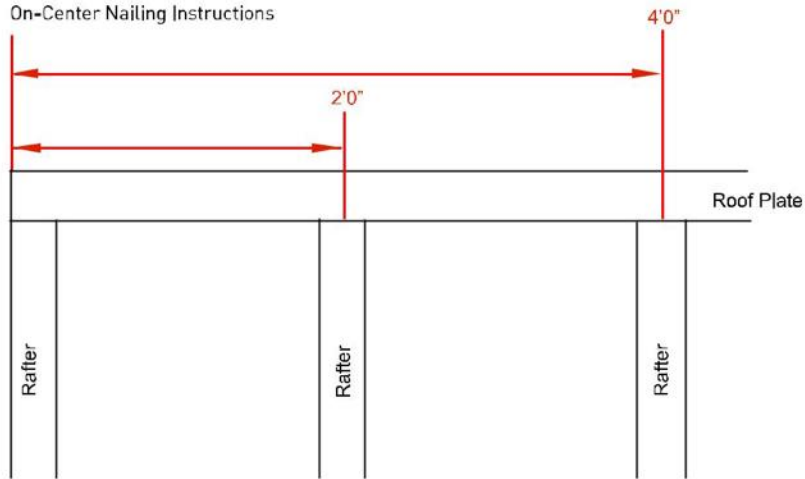

STEP 7. ENDING AT PHASE TWO-A

If stopping here, stack the finished walls on the slab and secure all remaining materials with the family.

PHASE TWO-B
>



STEP 4. DOOR INSTALLATION

Determine which way the homeowner would like the door to swing and pre-hang the door on a 2x4 hinge plate with the pins on top. Cut out the bottom plate. Center the door in the rough opening and nail the stud directly to the adjacent stud in the rough opening using only a couple of 16-penny nails. Check the full swing of the door and be sure there is ¼ in. of clearance all the way around. If the door swings properly finish the installation by installing the lock set. **Do not install 1x4 trim until step 17!**

STEP 5. PLACE THE ROOF SECTIONS ON TOP OF THE WALLS (D19)

The outriggers rest over the outside rake walls. Once the two sections are resting on top, nail them only to each other so that they are even. Center this joint above the middle rake wall. Leave an equal overhang on the 22 ft. sides of the house. Use a string line or a good eye to make sure your roof line is straight, and don't trust the top of the wall to be straight! Nail the high side of each rafter into the top plate of the wall in both directions (toenail), using two 16-penny nails per rafter. Finish squaring the roof by cross-measuring before nailing down the low side of the roof. When the roof is square, nail the outriggers and the low side of each rafter to the house in the same manner. If you do not have 30 ft. tape measures, measure from the top outside corners to the furthest rafter on the opposite edge. **The roof should not be more than ½ in. out of square.**

Locate all 8 hurricane straps in your materials. The straps are installed inside the house with 8-penny nails. A single house has two roof panels. The hurricane straps should be placed in all four corners of each roof panel (See Diagram 19).

STEP 6. PLACE BIRD-BLOCKS ON THE ROOF (D20)

Nail blocks between each of the roof rafters and each of the outriggers directly over the top of the wall **flush with the outside of the wall** (See Diagram 20). This is to prevent wind and birds from getting into the house after the plywood is on the roof.

This step must be well under way before starting Step 7. **The blocks are much harder to add after the plywood is on.** Since only a few people will be working on bird blocks, this is a great time for the rest of the crew to make tar squares (Step 14) and to start the bailing wire process (Step 11).

STEP 7. POSITION THE PLYWOOD ON THE ROOF (D21)

Stagger the plywood on the roof (Diagram 21). The ends of each sheet should meet together in the middle of a rafter. Cut a sheet of plywood in half for the ends of the middle row (Place cut edge out). **Pre-nail the corners of the plywood leaving the nail sticking up ¼ in. Do not completely sink any nails until the three rows of plywood are installed.** This allows warped rafters to be adjusted as each row falls into place. Nail four 8-penny nails in each rafter per sheet. **Never have more than 1000 lbs. or five people on the roof, and avoid standing in a group.**

It helps to use a chalk line when laying plywood. This ensures that the plywood will fit the roof squarely. Make chalk lines horizontally across the rafters at four and eight feet (the long horizontal lines in Diagram 21).

If plywood sheets don't meet on a rafter, it is often because of warped rafters. You should correct the rafter, straightening it while your partner nails. In cases where this is not enough, you should measure and cut a second rafter to be nailed adjacent to the rafter in question. This should also be done to rafters which are split or have knots.

Notes:

Handwritten notes area with horizontal lines.

D19

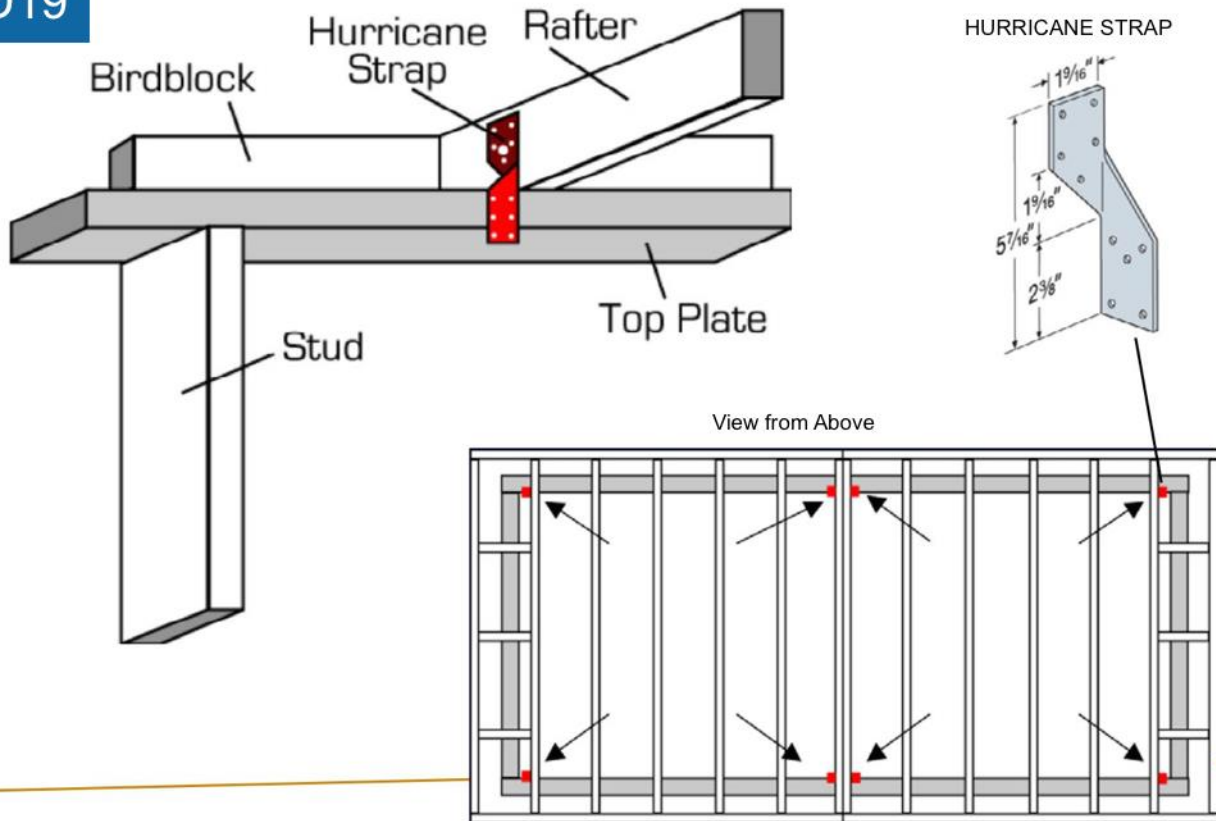

D20

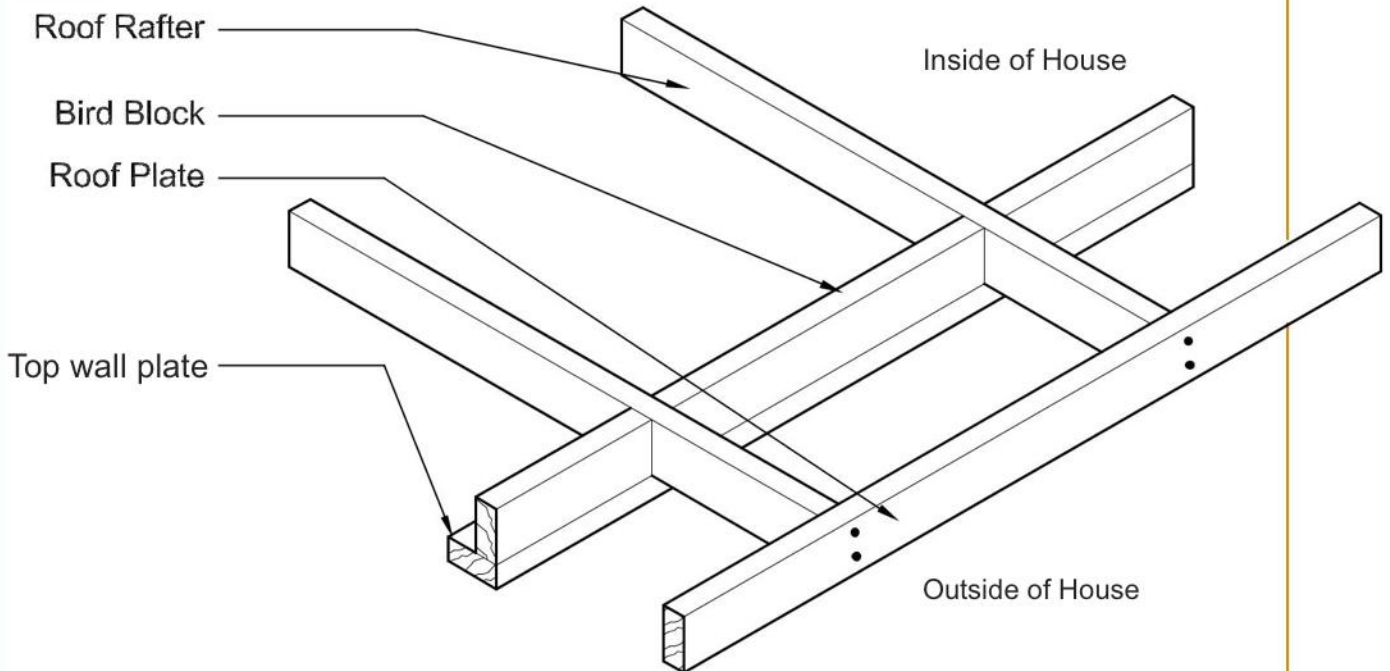

STEP 8. LAY THE FELT PAPER ON THE ROOF (D22)

After the plywood is securely nailed down, lay the black felt paper on the roof. Begin on the low side of the roof. Allow no more than 3 in. of paper to overhang each edge of the roof. Anything longer than 3 in. will need to be trimmed later. Once the row is straight and as flat as possible, nail the overhang down every one foot along the outside edges of the roof frame and every 2 ft. into a rafter along the top edge of the paper, using the 1 ½ in. roofing nails. **Do not nail the overhang through the plywood but rather through the side of the 2x4 roof frame** (Diagram 22). The next row overlaps the first by 3 in. On some rows, the paper roll will run out before the row is completed. Simply continue with a new roll and overlap the old section by 1 ft.

If you think you are behind you can do this step at any other point of the building process – even while you are stuccoing.

STEP 9. LAY THE ROLLED SAND-AND-TAR ROOFING PAPER ON THE ROOF (D23)

Follow the same pattern used for the felt, but nail the lower edge of the first row of paper every 1 ft. on the outside edges of the roof frame and the top edge every 2 ft. Make sure there are no

waves or bubbles in the roofing paper, or else water will build up on the roof and cause leaks. Roofing paper has a lot of sand glued to the front. It's easiest to cut from the back of the paper. Carefully drive the nails with a smooth face hammer so they don't rip the paper. Unlike the felt paper, the sand and tar paper requires some cold tar. After laying down each row, tar the top 2 in. of the paper so that the next row will cover it. Use a stick to pull the tar out of the can. A brush is provided to smooth out the tar. Nail along the tar line overlap every 2-3 in. **Make sure to use an unbroken roll of paper on each row.**

STEP 10. TRIM THE ROOF EDGE

Overlap the 1x4 so it meets flush at the corners of the roof. Take the 1x4 boards and nail them with 8-penny nails, two nails every two feet, around the face of the roof edge, covering the overlap of paper. Flush the 1x4 with the bottom of the outside rafter. This will prevent the paper from being weathered off the edges of the roof. Use smooth face hammers! Cut off any paper which protrudes beneath the 1x4.

After the roof is trimmed and everyone is off the roof, tar the nail heads on the roofing paper with the extra tar.

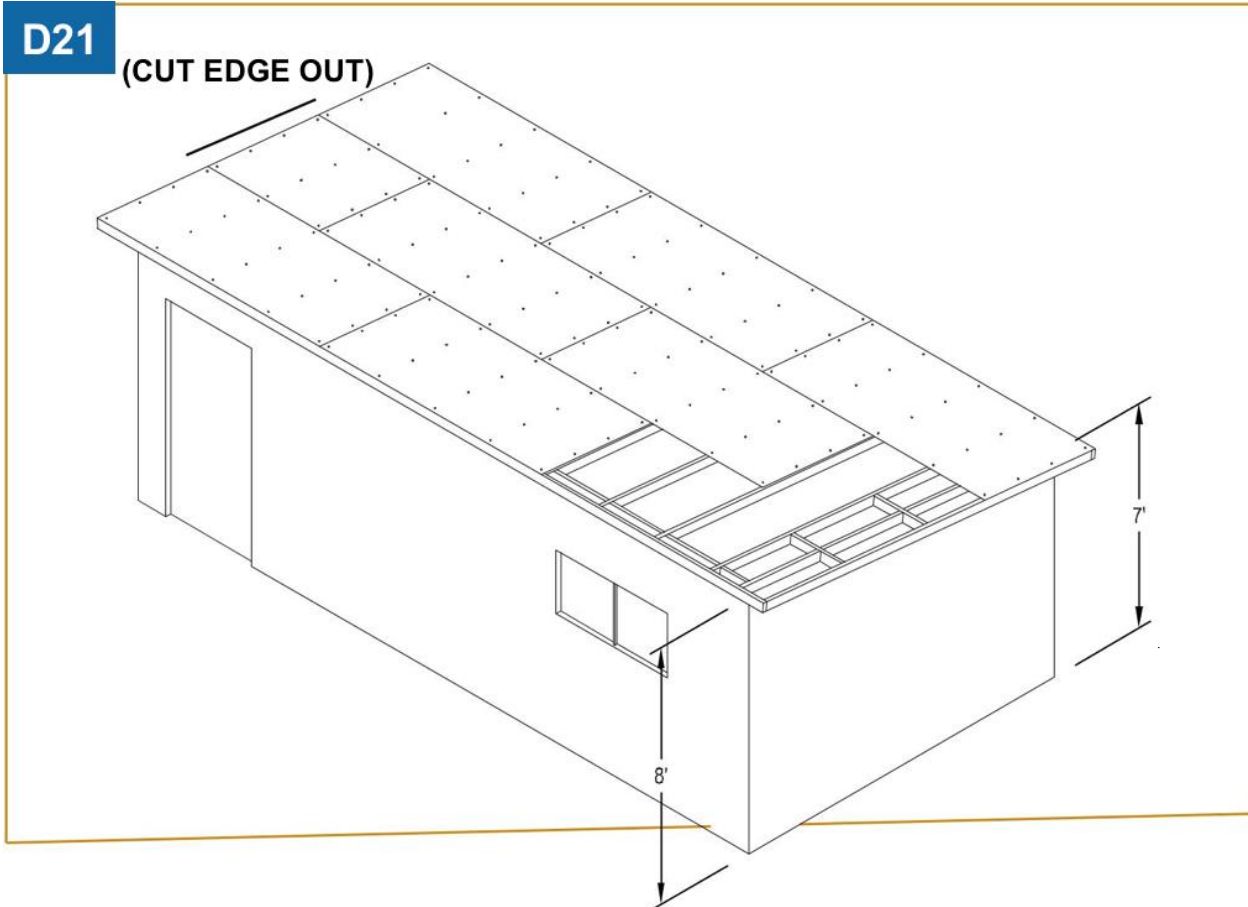

D22

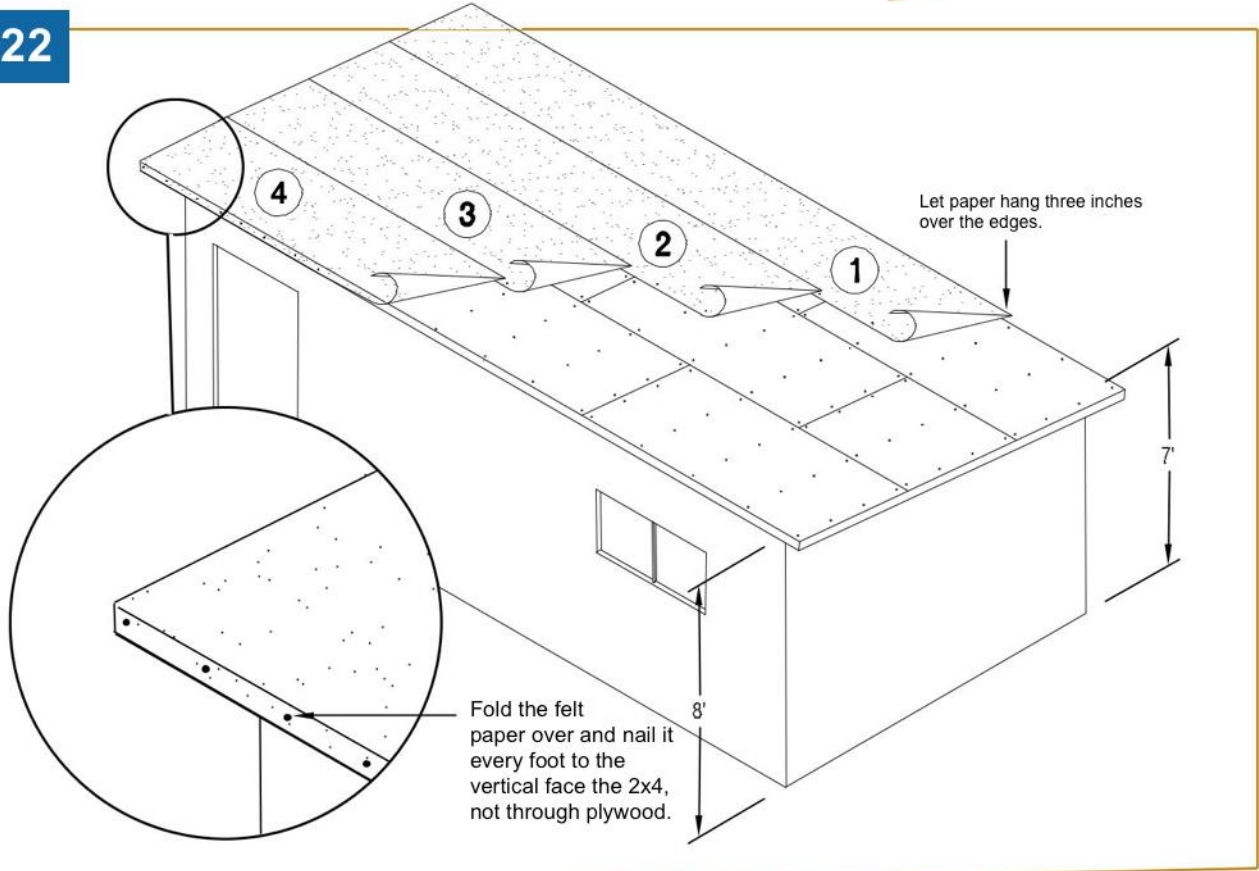

D23

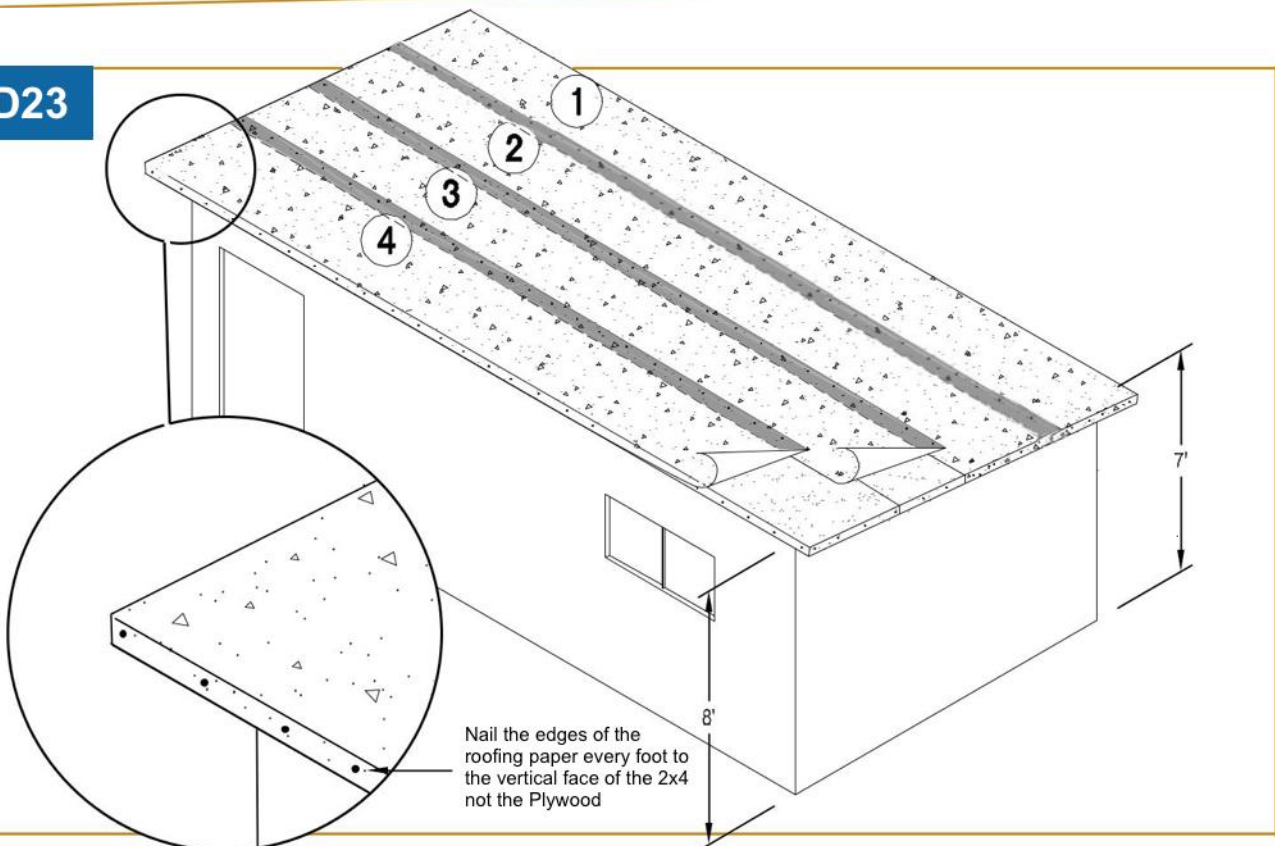

STEP 11. PREPARE BAILING WIRE

Bailing wire is needed as backing for the felt paper on the walls. Using roofing nails drive the nails in halfway to allow the wire to be wrapped around them. **The nails should be placed vertically in a line, 5 in. apart, on the end studs of every exterior wall section (six sections total) and vertically on the sides of window and door openings.** Do not wire across door or window openings. Wire should be strung tightly, and as free of kinks and bends as possible.

This step definitely calls for obeying the spirit of the technique, not the letter. What you're trying to achieve is a wall covered with wire with **no vertical gaps greater than 5 in.** This step can be done before the walls are stood, however, do not tighten (Step 12) the bailing wire until the wall section is plumbed and braced.

STEP 12. TIGHTEN THE BAILING WIRE (D24)

Tighten the wire by pulling up, close to the stud, on each wire and nail the wire into place. Move to the first stud which has not been nailed. Tighten the wire by pulling up on each wire that crosses the stud and nail the wire into place. Go to the next stud and push down on each wire and nail. Alternate this pattern until you reach the end of the wall. Do not overstretch the wire, and do not pull with hammers (See Diagram 24).

STEP 13. MAKING THE TAR SQUARES

Your group does not need to make or use tar squares unless you believe wind might blow the tar paper off, or if you plan to leave the paper up overnight without installing chicken wire. Plain roofing nails or a staple gun can be used instead of tar squares.

Tar squares are made from narrow strips of black felt paper and roofing nails and will be used later to secure the felt paper to the outside of the walls. Cut a strip of felt paper about 1 in. wide. Fold it over itself twice so that you have a 1 in. square of felt paper three layers thick and push the tip of a roofing nail through the center of it. This is known as a tar square and you will need about one full bucket.

STEP 14. PUT FELT PAPER ON THE WALLS (D24)

An easy method of applying felt paper is to pre-cut 18 11 ft. 6 in. pieces. **Start on the bottom and work your way up. Be sure to cover the top and bottom plates.** Align one of the pre-cut pieces with the lower edge of the bottom plate and run it full length. Make sure there are no bubbles or rips and nail with tar squares, one per foot on each stud. Overlap the bottom row by no more than 3 in. with the next row up. Nail each row the same way. If the paper has guidelines or other ink on one side, be sure to place that side facing the outside of the house, as the inside of the walls may not be finished. Three rows of paper should cover a wall. On the rake walls, hang the top piece of felt paper at an angle, flush

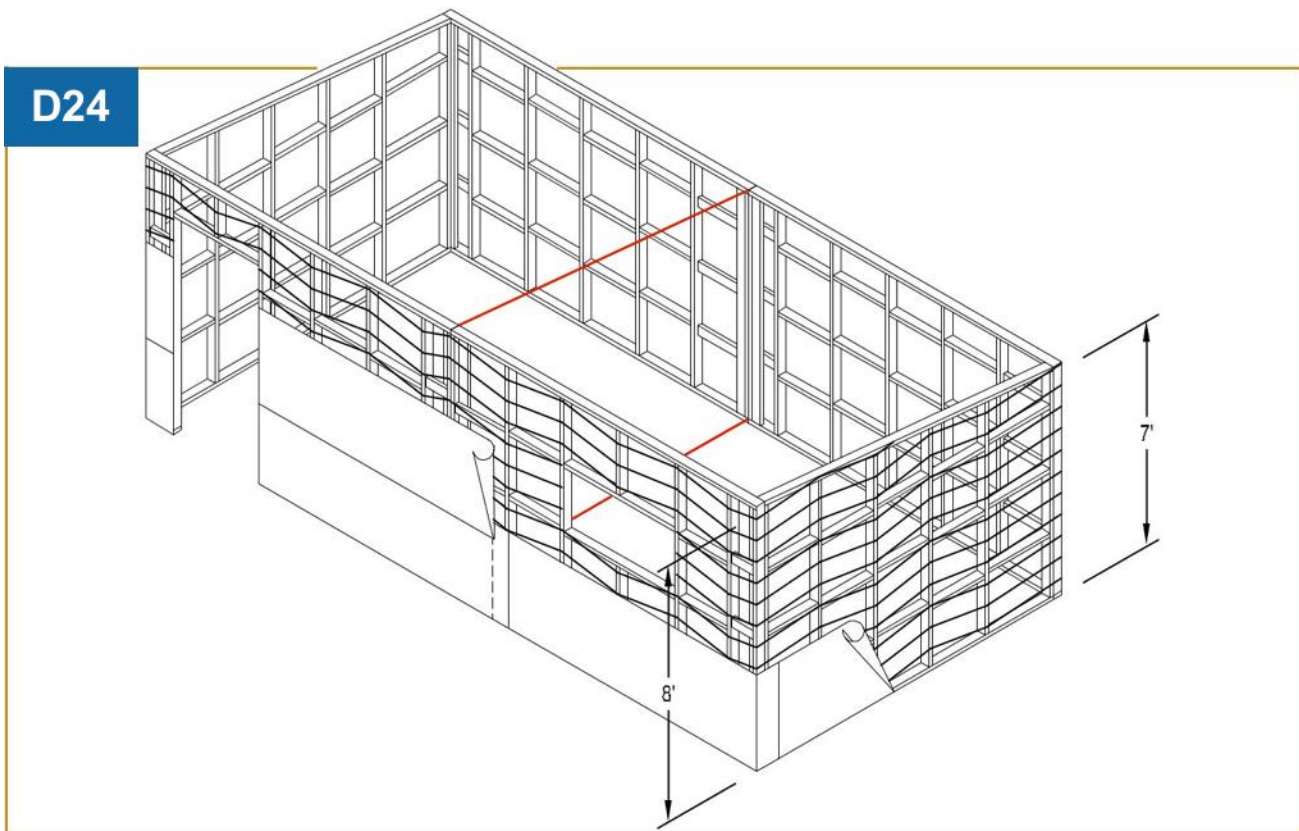



with upper edge of the top plate. If you do each wall separately, be sure one-side wraps around the corner to avoid open seams.

It helps to nail the top edge of a row of paper first, and let gravity help you with the rest as you nail across the middle and bottom of the paper. Cut paper flush from window and door openings.

You can repair holes in the paper quite easily. Just slip a scrap piece of tar paper behind the hole, between the paper and the bailing wire. Some teams prefer duct tape and bring their own.

Loose bailing wire can leave deep pockets in the felt paper for stucco. Rolled scraps of felt paper can be worked into slack areas between bailing wire and paper to push out bubbles for flatter stucco surface.

STEP 15. STRETCHING THE CHICKEN WIRE (D25)

Two rows of chicken wire will cover every wall section. The wire should be as tight as possible, with no bubbles, or gaps larger than a normal (hexagonal) chicken wire hole.

This is the most efficient method we have found for stretching chicken wire:

Prepare the top and bottom of all the walls with a row of roofing nails in the top and bottom plates, 6 in. apart; leave the nail heads sticking out ¼ in.

Beginning in the doorway leaving 1 ft. of extra material, wrap the house with one continuous piece ending at the same doorway with the same amount of extra material. Tightly (be sure it's straight too) hook the bottom (double-strand) wire to the nails and finish the nails in the bottom plate all the way around the house. The wire will be sagging off the house. Do not worry.

Go to the four corners of the house and stretch the wire up the wall as far as possible and nail it. Once the corners have been stretched, move onto the door opening. Stretch the wire in the same way and finish nailing the door frame every 4 in.

Now, working your way from stud to stud, starting in the middle of each wall section, estimate the distance you can stretch the wire. Place a nail in the stud, ¼ in. exposed, then stretch the wire and hook the top (double-strand) wire onto the nail. Finish the nail off before moving to the next stud. You will find bubbles under a stretched stud can be removed when stretching at the next stud. After the entire wall is stretched, add nails, one every foot vertically on each stud, and two nails on each fire block.

With a new roll of wire, in the same way hang the second row of chicken wire from the top plate, beginning in the middle of the door. Leave enough extra material to overlap the seam at the

door. Follow the same procedure as before in stretching the wire down the wall. Before cutting the wire out of the doorways and windows, thoroughly nail chicken wire every 4 in. around openings to maintain the tension in the wire.

If you still have bubbles in the chicken wire after your best stretching efforts ask an Amor Team Member for guidance.

STEP 16. WINDOW INSTALLATION

Be sure to check and see that the window is placed right side up with the latch locking down and on the inside. Then slide the window into place from the outside of the house. Finally, if your windows do not have a channel to fit 2x4's into, nail the window into place with the short green 8-penny nails; drive the nails through the inside of the window and into the vertical studs that frame the sides of the window. Be sure to remove the sliding portion of the window while you do this. You may find that it's hard to drive the nail all the way in due to the way the window is built. Take a 16-penny nail and turn it upside down to be used as a nail punch. If your windows have the channel for the 2x4's, insert the 2x4's into the sides of the windows, slide the windows into place from the outside of the house, and use the large 16 penny nails to nail from the top and bottom horizontal studs into the 2x4's in the channels of the windows. (Follow the diagram on Page 8).

!! Do Not Trim The Windows!!

We do not provide enough material to trim the out the windows.

STEP 17. TRIM THE DOOR (D26)

The 1x4 acts as a doorstep. Using 8-penny nails, surround the inside of the door jam with 1x4 trim. This will also act as a place for the stucco to end at the door. Cut and fit the 1x4 such that it slides sideways into the door jamb, the 1 in. side butting up against the door (See Diagram 26). Use a smooth face hammer when nailing the trim.

Notes:

Handwritten notes area with horizontal lines.

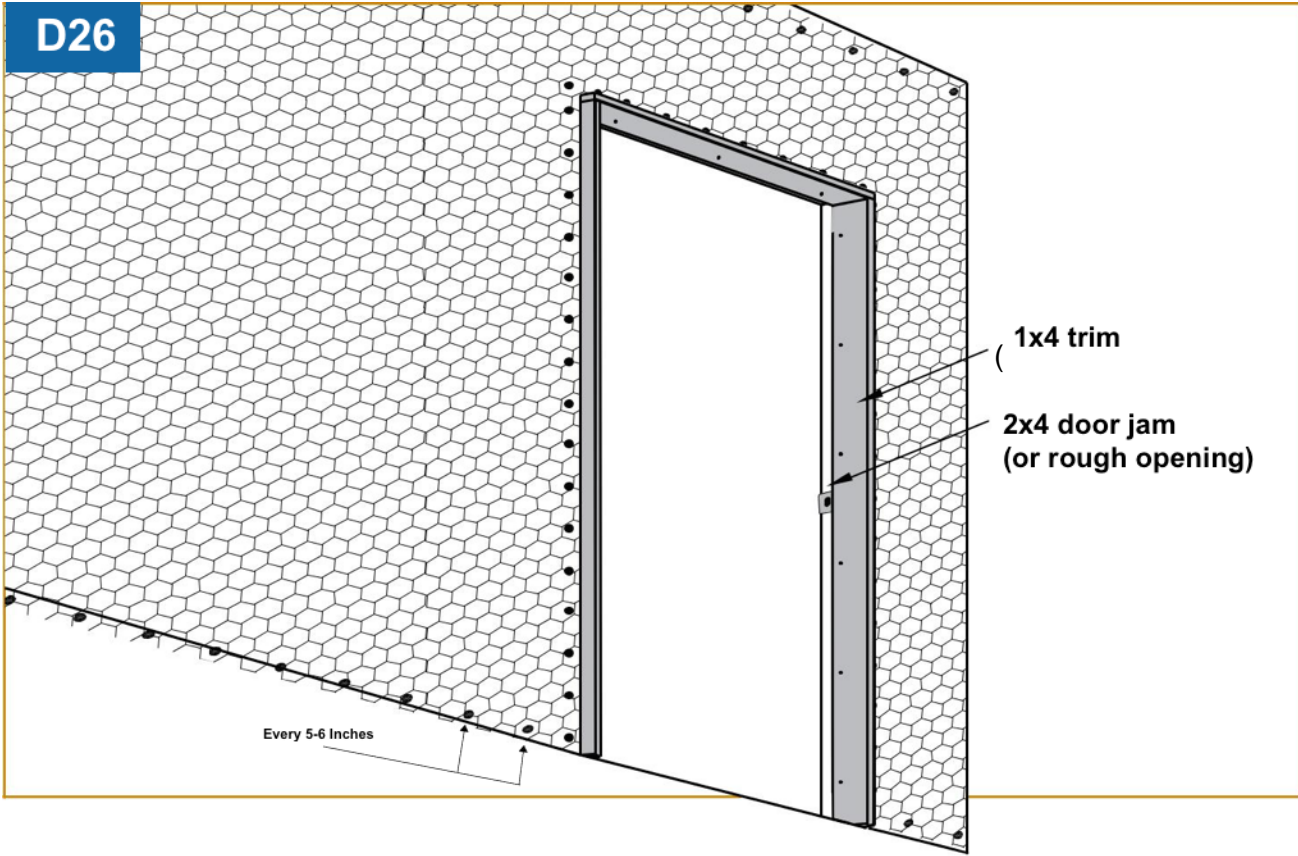
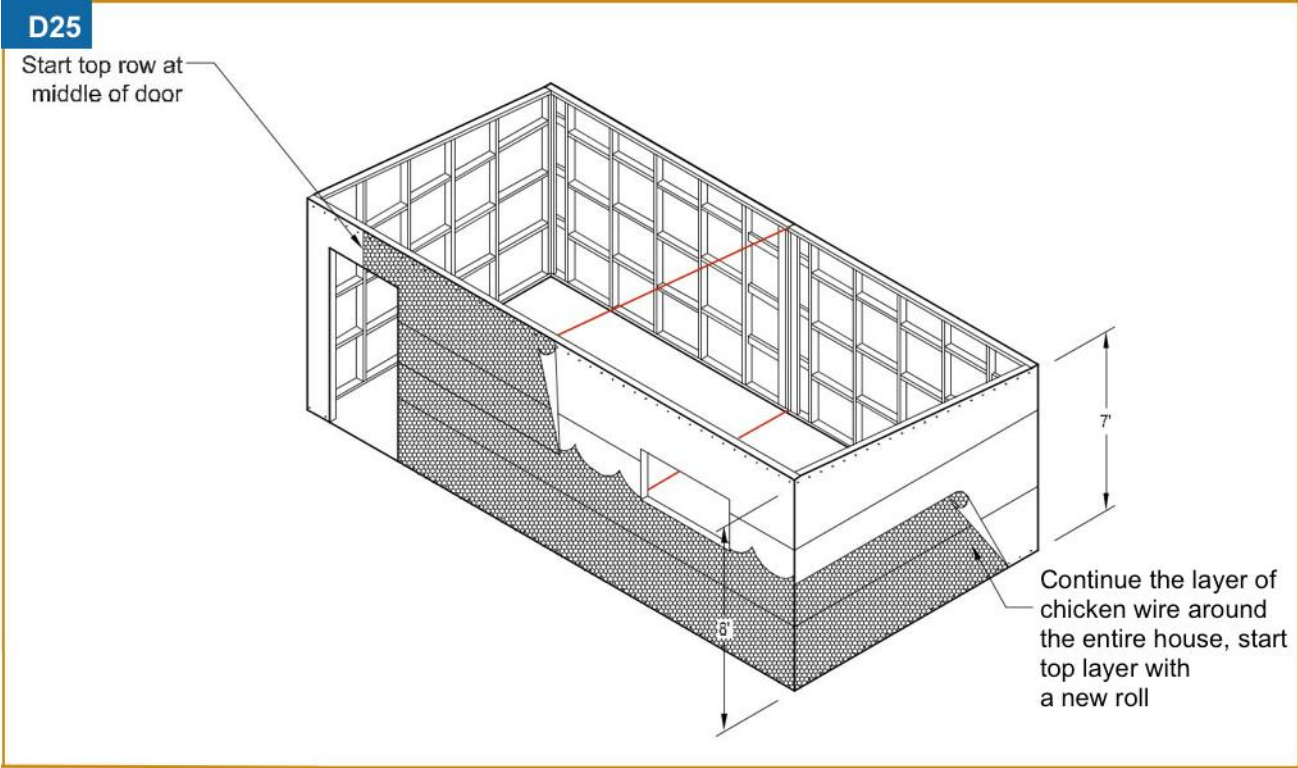



Tool Inventory

- When finished with your rental tools each group should...
- 1. Empty out your tool bin COMPLETELY (please no trash, loose nails, etc.)
- 2. Clean ALL tools! Ladders, Mixing Bins, Wheelbarrows, Cement Tools)
- 3. Inventory ALL your tools on this sheet and tell us what is missing.
- 4. Place the inventory sheet inside the tool bin, on top of the small tools.
- 5. Groups renting only large tools should tape the list to a Wheelbarrow

| Herramientas Grande | Deben | Falta | Herramientas Pequena | Deben | Falta |
|---------------------|-------|-------|----------------------|-------|-------|
| Carretillas | 2 | | Serruchos | 6 | |
| Cajas para mezclar | 3 | | Martillos | 15 | |
| Cubetas | 5 | | Barreta | 1 | |
| Palas Redondo | 6 | | Navajas | 4 | |
| Palas cuadrada | 2 | | Corte de Alambre | 4 | |
| Azadones | 6 | | Flexometros | 6 | |
| Rastillos | 2 | | Escuadras, Grande | 1 | |
| Pico | 2 | | Escuadras, Chica | 4 | |
| Escaleras | 2 | | Hilo de chalk | 1 | |
| Cernidor | 1 | | Pata de Chiva | 1 | |
| Nivel de 4' | 1 | | Llanas | 10 | |
| Group Name | | | Lapis | 5 | |
| Family Name | | | Sargentos rapido | 2 | |
| | | | Ceppillo de alambre | 1 | |
| | | | Marro | 1 | |
| Project ID# | | | Formones | 1 | |
| | | | Desarmador | 1 | |
| | | | Charolas con mango | 10 | |
| | | | Nivel de 2' | 1 | |
| | | | | | |

| LARGE TOOLS | YOU SHOULD HAVE | ITEMS YOU ARE MISSING | SMALL TOOLS | YOU SHOULD HAVE | ITEMS YOU ARE MISSING |
|---------------------|-----------------|-----------------------|-----------------------|-----------------|-----------------------|
| Wheel barrows | 2 | | Saws | 6 | |
| Mixing Tubs, Large | 3 | | Hammers | 15 | |
| Five-Gallon Buckets | 5 | | Pry Bars | 1 | |
| Shovels, Round | 6 | | Utility Knives | 4 | |
| Shovels, Square | 2 | | Wire Snips | 4 | |
| Hoes | 6 | | Tape Measurers | 6 | |
| Rakes | 2 | | Squares, Large | 1 | |
| Picks | 2 | | Squares, Speed/Tri | 4 | |
| Ladders | 2 | | Chalk Lines | 1 | |
| Sand Sifter | 1 | | Nail Pullers | 1 | |
| 4' Level | 1 | | Trowels | 10 | |
| Group Name | | | Pencils | 5 | |
| Family Name | | | Clamps | 2 | |
| | | | Wire Brush | 1 | |
| | | | Hand Sledge | 1 | |
| Project ID# | | | Wood Chisel | 1 | |
| | | | Phillips Screw Driver | 1 | |
| | | | Hawks | 10 | |
| | | | 2' Level | 1 | |
| | | | | | |